



# Product Brochure



# X900

## Commercial Electric Treadmill

1. 23.8-inch large screen LCD display, touch screen, with rotation function; Mobile wireless charging, USB interface, online browsing WIFI、 Bluetooth connectivity

2. Switching between Chinese and English languages (text); Multiple options including volume, brightness, automatic shutdown, settings interface, third-party application interface, sports interface, sports projects, interface, login interface, personal information settings interface, real-time running interface, and time interface

3. Display: speed, slope, calories, heart rate, time, program mode, distance;

4. Power: AC \ 220V-250V 5. Motor: GB-F grade 3HP \ 50Hz commercial treadmill specific motor

6. Drive Control: VFD AC Dynamic Variable Frequency Response Drive System

7. Speed Range: 1.0--20km\h

8. Slope Range: 0-15°

9. Effective running area: 580\*1599mm

10. Running Board: Design of MDF25mm wear-resistant layer and pre wax anti-static process

11. Shock Absorption System: Designed with silicone 0-type cushioning technology

12. Load Bearing Capacity: 180kg

13. Floor Area: 2078\*845\*1680mm

14. N.W: 178kg

15. Dimensions: wooden box 2100\*870\*310mm / cardboard box 870\*870\*280mm

# X1100

## Commercial Electric Treadmill

1. 23.8-inch large screen LCD display, mobile phone screen projection, with rotation function; USB interface, online browsing WIFI, Bluetooth connection, Chinese English text interface

2. LED Console: LED Display: Speed, Slope, Calories, Heart Rate, Time Program, Mode, Distance; Quick selection keys for speed and slope, volume adjustment, sports mode program selection key, Bluetooth switch selection key, start key, pause key

3. Power: AC \ 220V-250V    4. Speed Range: 1.0-20km/h    5. Load bearing: 180kg

6. Motor: GB-F grade 3HP \ 50hz commercial treadmill dedicated motor    7. N.W: 172kg

8. Drive control: VFD AC dynamic variable frequency response drive system, overload protection function

10. Slope Range: Positive Slope 0-15° \ 13001b \ Negative Slope 0-3 ° Two slope selection functions

12. Effective running area: 558\*2.5\*1545mm \ Standard sports engineering range

14. Shock absorption system: Designed with progressive 0-type silicone cushioning technology

9. Dimensions: wooden crate 2165 \* 915 \* 495mm

11. Floor area: 2127 \* 892 \* 1560mm

13. Running Board: MDF25mm wear-resistant layer, pre wax anti-static process design



**X1100A**

LCD Rotating Screen

**X1100B**

No Screen Style



# X700

## 2 IN 1 Function Crawler Treadmill

1. X700 adopts high-end overall design combined with high-tech concept, which can make users experience in more aspects. Modes are divided into ① . Quick Start ② . Manual mode ③ . User mode ④ .P program (there are six P modes) ⑤ . Unpowered mode ⑥ . Resistance mode. Function Display: lap, slope, time, mode, pulse, calories, distance, speed. It provides a variety of choices for users with different needs.

2. X700 treadmill adopts crawler running belt, which is formed by advanced composite materials and incorporated into a soft shock pad to meet the requirements of high service life under strong load. Weight capacity high shock absorption, reducing resilience while absorbing the impact force of stepping, which can more effectively reduce the trigger pressure of the knee and protect the knee. At the same time, this running belt also has no requirements for training shoes, which can be barefoot and has a long service life.

3. The speed can be adjusted to 1 to 20 gears in normal mode, and the resistance value can be adjusted from 0 to 10 in resistance mode. Slope lifting support 0 ~ + 15%; 1-20km speed adjustment, one of the keys of indoor running knee support lies in the angle of treadmill, most people running angle between 2-5 ° . The slope of a higher angle is conducive to improving exercise efficiency and meeting various needs of customers.

4. Emergency brake switch is attached with safety latch and rope, which is more convenient to operate and use.

5. Its materials are solid, max load up to 200kg running without shaking, enjoying the feeling of smooth running.

6. Adopt vertical screen design to protect spine healthier. There are water bottle cage on the left and right sides of the screen respectively, which is convenient for users to replenish water and can also place other portable small objects. Wireless charging set is provided in the middle, eliminating users' worries about charging their mobile phones.

7. Equipped with heart rate grip, it can detect user heartbeat in real time.

8. The motor adopts the stable and continuous power output of 3HP high-power motor, which easily loads users of different weights.

9. Product Specification size: 2065\*940\*1720mm (length \* width \* height)

10. Net weight: 233KG



**X710A**  
LED Display

**X710B**  
LCD Display

# X710

## Electric Treadmill

1. The X710 adopts a high-end overall design combined with high-tech concepts, which can provide users with a more diverse experience. The speed can be adjusted to 1-20 gears, and the slope can be raised or lowered by 0-20°; The key to adjusting the speed of 1-20 km/h for indoor running is the angle of the treadmill, which is between 2-5 ° for most people. A higher angle slope is beneficial for improving exercise efficiency and meeting various customer needs.
2. The emergency brake switch is equipped with a safety pin and rope, making it more convenient to operate and use.
3. Its materials are solid and can bear up to 200 KG without shaking during running, enjoying a smooth running experience.

4. Adopting a vertical screen design to protect the spine for better health. There are kettle racks on both sides of the screen, making it convenient for users to replenish water and place other small items with them. There is a wireless charging stand in the middle position, which eliminates the hassle of users charging their phones.
5. Equipped with a heart rate grip, it can detect the user's heart rate in real-time.
6. The motor adopts a 3HP high-power motor with stable and continuous power output, making it easy to load users of different weights.
7. Product dimensions: 1885 \* 950 \* 1705mm (length \* width \* height)
8. Net weight: 202kg



# X600

## Commercial Treadmill

1. This product absorbs foreign high-end design inspiration, the overall shape is beautiful, subversive column design combined with the most popular creative elements, instantly highlights the treadmill's dignity and luxury.
2. The design of center console supported by ultra-wide aluminium alloy column provides a stable and reliable working platform for users.
3. The emergency brake switch is equipped with a safety clip and a tether, which is located in a prominent position below the front end of the armrest for easy use by the operator. It is safe and reliable to stop operation immediately when emergency power failure occurs. The heart rate monitoring device designed on the handle can detect the user's heart rate in real time and feedback the user's ideal heart rate state in time.
4. The design of the kettle rack on the left side of the central console is divided into two parts. It can not only place round kettles to facilitate users to replenish water in time, but also place keys, membership cards and other small items for easy access. The long storage tank designed in the middle position can hold mobile phones, tablets and other items, while doing sports while chasing dramas, sports and entertainment are both going on. On the right side of the slot, a wireless charging function is designed, which eliminates the user's charging worries. At the same time, the instrument table has designed a fast direct selection button, which facilitates users to choose slope and speed quickly, and brings users different experience.

5. Unique fan design under the display screen, using automobile -grade drum fan, large volume of wind, gentle wind, one-button switch, so that users can experience the pleasure of spring breeze while running.
6. The runway adopts a high elastic silica gel shock absorber system, a new design concept, with a widened runway structure, so that the athletes can reduce knee injury in the intense sports environment.  
Running area: 1630x600 mm.
7. Innovative -3 degree gradient design brings a brand-new experience of gradient selection, users can choose more modes.  
Running speed: 1-20 km/h.
8. The machine routinely sets nine automatic training modes and easy to operate, providing users with different requirements with a variety of choices.
9. The motor uses 3HP high-power motor, a real high-end commercial treadmill, easy to load users of different weights.
10. Product Dimensions: 2320\*965\*1695mm (LxWxH)
11. Net weight: 201 kg, gross weight: 223 kg
12. Maximum load: 200 kg

# X500A/B

## Commercial Treadmill

1. X500A/B adopts new design idea of North America, which makes X500A/B more succinct, massive and steady. The perfect combination of several advanced technology highlights noble and luxury. X500-A is a button version
2. The new frame design makes the center console extremely stable, providing a stable & reliable experience and quiet & comfortable use for exercise.
3. The emergency brake switch is equipped with a safety clip and a lanyard to stop the treadmill when the power is turned off. The lanyard and the safety clip can be attached to a protruding portion located at the lower portion of the front end of the armrest, which is very convenient for the exerciser to operate.
4. Two bottle cages will accommodate the exerciser's mobile phone in place and keep it in the center of the front, leaving enough room for keys, membership cards, etc.
5. The new and improved progressive damping system absorbs high impact motion and supports stable and controllable depressions.

6. Decline and Incline support -3% to +15%, capable of simulating various terrains; speed 1-20KM/h to meet various needs of customers.
7. Specialized 9 automatic training modes;
8. The motor uses continuous power 3HP high-power motors (220V, 60HZ, 9.8A) to easily drive a variety of different loads.
9. Running belt size 3325\* 558mm (effective use size 1420\*558mm)
10. Product Dimensions: 2125\*890\*1730mm (length\*width\*height)
11. Net weight 158kg, gross weight 180kg
12. Maximum load: 200kg



# X800

## Surfing Machine

1. Improve body balance, coordination and exercise sensation; Improve core strength and stability; Effectively prevent injuries by improving muscle energy absorption capacity; Under the condition of maintaining body balance, the lower the center of gravity of improving physical fitness, coordination and core stability (more functional), the more energy the limbs absorb, the greater the training intensity; Provide users with shaping training, hip beauty, leg beauty; Increase the impact or stimulation of muscle tissue caused by gravity or speed.

2. Multi-function display dial, high-definition data display: Control your own sports data at any time, reasonably customize sports fitness plans, and make scientific fitness more dedicated.

Ideal handrail position: The ergonomic handle position and bending angle allow people of different bodies to hold it easily. During exercise, the hands and shoulders can extend forward moderately, making the movement more comfortable, and achieve the effect of hand movement

Adjustable base: Improve the balance, core strength and stability during physical exercise

3. Floor space: 2090\*1135\*1485mm

4. Net weight: 225.5KG

5. Function display: time, speed, fitness guide

6. Drive mode: motor drive





# D20

## 2 IN 1 Function Rowing Machine

1.The rowing machine is a surface resistance, friendly to the heavy and injured, and can burn fat efficiently In the process of exercising, it will not cause damage to the body due to the influence of weight.The fat loss exercise is extremely high, and one action can mobilize more than 80% of the potential of the whole body

2. This rowing machine has the dual functions of wind resistance and magnetic resistance in one

·The wind resistance rowing function mainly depends on the combination of the blades and the tuyere. When the blades rotate, the air is squeezed to produce resistance. When the tuyere is small, the air inside cannot be discharged, and the resistance naturally increases.

·The magneto-resistive rowing function uses a magnetic field as a medium, and uses a metal flywheel and a magnet to generate resistance, which is more convenient to adjust the resistance.And because the magnetron does not generate friction, it is ultra-quiet.

Feel: more even and smooth resistance

Appearance: full of metallic

Storage: Relatively more space

Resistance size: multi-speed adjustable resistance

Maintenance: easy maintenance, anti-build

Size: 2405\*625\*1145mm

Wind resistance gear: 1-10 gears

Magnetic resistance gear: 1-8 gear

Type: Detachable

Maximum load: 150kg

# X510

## Elliptical Machine



Adjustable natural gait slope  
Adjustable slope 10° -35°  
20 resistance levels  
Weight: 154 kg

Power Supply: Self-generating  
Heart rate monitoring: Yes  
Size:(length \* width \* height):203 \* 76 \* 183 cm

Natural, low-impact stride exercise and proven reliability benefit you from every workout, while allowing you to enjoy consistent reliability and superior performance. The X510 elliptical training machine provides you with a cushioning exercise experience that matches the natural movements of the body and allows you to benefit more from your fitness.

The natural gait slope is adjustable, and the user can adjust the slope at a range of 10° -35° ,and conduct independent or crosstraining for specific muscle groups in the lower body to easily achieve the exercise goal.

The new adjustable gradient design of natural gait can better simulate the natural gait movement path during walking and running.

Easy to maintain, X510 is easy to clean and maintain, inheriting consistent reliability and thoughtful service.

In order to extend the service life of the active state indicator, the equipment is equipped with an external state indicator. With this indicator light, you and your staff can see clearly the operating status of the elliptical trainer and know when the equipment should be maintained.



**X510B**  
LCD Display



**X511**  
Simplified Configuration



**X511B**  
LCD Simplified Configuration



**X520**  
LED Display

**X520B**  
LCD Display

# X520

## Recumbent Bike

Product Dimensions: 1075\*585\*1370mm(length\*width\*height)

Driving Mode: Self-generating Motor

- Aerobic exercise, enjoy pure physical fitness, physical health and body shaping, easy exercise
- HD dashboard, adjustable and multifunctional, time, distance, calories, speed, Watt, heart rate

N.W:77kg

Heart rate monitoring: Yes

Maximum load: 150kg

Resistance Range: 0-20 (segment)

- Special low noise design to ensure a quiet environment
- Rotary pedal, non-slip and not easy to wear, enhanced fit

# X530

## Upright Bike

Product Dimensions: 1125\*525\*1565mm(length\*width\*height)

Driving Mode: Self-generating Motor

- Simple instrument design is clear and clear, making sports more clear
- Control exercise intensity reasonably according to the monitored heart rate to obtain effective exercise effect
- Carefully polished and adjusted to ensure smooth riding of high-speed sports, smooth and smooth
- The cushion can be adjusted back and forth to meet the sports needs of different heights and angles.

N.W:62.5kg

Heart rate monitoring: Yes

Maximum load: 150kg

Resistance Range: 0-20 (segment)





# X300A

## Arc Trainer

**Product Size:** (Long \* Wide \* High) 1765\*970\*1650mm

**Product Name:** X300A Arc Trainer(3 in 1 function)

**Resistance Value:** 900W 180rpm

**Slope Section:** 15

**Step Length:** 61cm

**Maximum Loading Weight:** 150KG

**Power Supply:** Self-generating

**Program:** Manual mode + Automatic mode

**USB:** Cell Phone Charging Function

**Heart Rate:** contact type.

**Function:** Elliptical, Skiing, Climbing

Whether it is beginners or sports enthusiasts, our highend X300A arc step trainer uses a spontaneous reluctance motor, and the size of the step can be adjusted to make the movement faster, safer, and more effective. According to foreign authoritative fitness institutions, it burns up to 16 % more calories than competitors such as elliptical machines or crosstraining machines. The knee pressure decreased by 83 %. Muscle endurance increased by 38 %. In addition, it can also significantly enhance strength training, cardiovascular health improvement This device is designed for lower extremities, upper extremities training and fullbody climbing exercise.

The display program setting provides the user with a convenient control center that can set up an exercise plan. An independent control center, free to choose the exercise program. Members can easily set up exercise programs to charge the iPad or iPhone.

Our highend arc training equipment is solid and reliable, with low maintenance costs. After testing and verification of the three in one machinery, to practical and simple design, showing our high quality sports structure performance and health advantages. This highend arc training device is designed specifically for users and environments that value health over vanity. Our device offers complete options for weight loss, strength, and caloric exercise. Therefore, with a machine can meet the different needs of beginners and advanced athletes, so that you can easily enjoy health.

Our equipment is perfect for these exercise areas such as hotels, corporate fitness centers and families. The device offers a wider range of slopes and resistance, and it is no exaggeration to say that it has the function of having three devices in one device. Taxing like crosscountry skiing at low slope levels; A stepwise movement like an ellipsoidal machine at a medium slope level; At a high slope level, crawling like a stair. At any level of slope, the same traditional calorie consumption and safety are transmitted.

# Warrior Series

## Vertical Climber

### Warrior100

Manual Vertical Climbing Machine



- 1. **Model:** Warrior100
- 2. **Name:** Climber
- 3. **Product weight:** 45.5kgs
- 4. **Length/width/Height:** 1095\*1050\*2420mm
- 5. **Steel tube size:** Square tube 50\* 1000\* 2.5mm
- 6. **Climbing angles:** 70°
- 7. **Feet climbing height:** 540mm
- 8. **Safe Max load:** 120kg

**9.Character:**  
Climber workout saves you valuable time while delivering the most effective fat and calorie burning workout available. Studies have proven a Climber workout burns more fat and calories in 15 min than Treadmills, Ellipticals, Steppers, and Bikes. When it comes to getting in shape, dropping unwanted pounds and building a stronger healthier heart, Climber offers the most effective, complete, total body work out available of any cardio equipment.

- 1. **Model:** Warrior 200
- 2. **Name:** Climbing Machine
- 3. **Product Weight:** 95KG
- 4. **Product Size:** 1095\*1050\*2420mm
- 5. **Pipe Material:** steel
- 6. **Climbing Angle:** 75°
- 7. **Stride Distance:** 540mm
- 8. **Safe Max Load:** 120KG
- 9. **The Resistance Can Be Adjusted:** 20 stalls
- 10. **input Power Supply Voltage:** AC220V ± 10%
- 11. **Power Cord Specifications:** 10A AC250V
- 12. **Time Display Range:** 0:00 -99:59
- 13. **Height Display Range:** 0.00 999.9m
- 14. **Heat Display Range:** 0- 999(Kcal)
- 15. **The Number of Steps Display Range:** 0-9999



### Warrior200

Motorized Vertical Climbing Machine

# Y600

## Non-motorized Treadmill



### Y600A

Self-propelled Treadmill  
(Aluminium Running Belt)

### Y600B

Self-propelled Treadmill  
(Nylon Running Belt)

1. **Motion mode:** 1-8 levels adjustment
2. **Braking mode:** magnetic resistance adjustment
3. **Running Belt:** crawler -type Belt; Aluminum Alloy Frame work or High Strength Nylon Framework is optional
4. **Running machine size:** 1850\*860\*1580mm
5. **Running belt size:** 3600\*480mm
6. **Drive mode:** gravity driven
7. **Speed limit:** 0 -20 km/h
8. **Running area:** 1500\*430mm
9. **Maximum user weight:** 180 kg
10. **Net weight:** 150.5kg
11. **Gross weight:** 185kg
12. **Packaging size:** 1800\*1000\*560mm

# X200

## Stair trainer

- 1. **Space Floor:** 1510\*780\*2230mm
- 2. **Step height:** 210 mm
- 3. **Step effective width:** 560mm
- 4. **Net weight of instrument:** 197KG

- 5. **Drive mode:** motor driven.
- 6. **Motor Specification:** AC220V- 2HP 50HZ
- 7. **Functional Display:** Time, Climbing Height, Calories, Steps, Heart Rate

◆ Stair trainer is able to exercise the muscles of the whole body, strengthen bones, train body balance and flexibility, quickly carve body shape

**X200B**

Standard Configuration

**X200E**

LCD Display





# X200D

## Non-motorized Stair Trainer

- 1. **Product Dimension:** 1155\*780\*1995mm
- 2. **Net weight of instrument:** 210KG
- 3. **Resistance Mode:** Reluctance control
- 4. **Gear Level:** 8 adjustable gears
- 5. **User Weight:** ≤ 150kg
- 6. **Transmission Mode:** Chain transmission
- 7. **Braking Method:** Brake band
- 8. **Number of Steps:** 6 sections

# Exercise Bike



## D12 Exercise Bike

The bicycle let the exerciser's whole body fully participate in sports and gains a truly dynamic and adjustable exercise experience. At the same time, it improved physical fit, fitness experience and service life, allowing exercise people to enjoy the dreamed riding experience.



## D13 Commercial Air Bike

The bike has flexible personalization, allowing the trainer to maintain the target heart rate in low-intensity projects and also can switch quickly to the challenging high intensity intermittent training.



## D14 Exercise Bike

The product adopts strong and durable design and is equipped with a certified chain driven system and high strength crankshaft, can provide excellent strength and durability, to meet the needs of all exercisers.



## D15 Magnetic Exercise Bike

The zero contact gear and poleless magnetic drag of the bicycle is free of extreme magnetic resistance and it can adjust the resistance at will. It brings you unprece dented riding feelings, and its poleless resistance device can freely adjust, by which can bring you suitable resistance level.



# D12

## Exercise Bike



- ① The pedal installation adopts Mohs taper, which is more closely coordinated and not easily damaged;
- ② Drive multiwedge belt scheme;
- ③ All use 19.5 kilograms ( 43 pounds ) of peripheral plus heavy flywheels. Add flywheel the weight of theperiphery can increase the inertia and help the bicycle to achieve smooth and smooth exercise ,offering outdoorrides closer to any other fitness car experience;
- ④ Aerodynamics and circular design, conducive to perspiration, and easy to clear cleansing and maintenance.All aluminum adjustable extenders and stamped post stabilizers the parts that need most rust protection will not rust;
- ⑤ Oversized steel frame, better overall corrosion resistance, appearance and stiffness obtained promotion;Equipped with front and rear handle adjustment and stronger anticorrosion aluminum stabilizer.
- ⑥ Device size and weight:  
Length + width + height: 1330\*525\*1220mm  
Weight: 63 KG

# D13

## Commercial Air Bike



**Model:** D13

**Name:** Commercial Air Bike

**Product weight:** 59kgs

**Length h/width/Height:** 1365\*610\*1440mm

**Steel tube size:** Flat Oval tube 97\*40\*2. 5mm

**Character:** The great thing about the Airbike is that it can work for a beginner, a rehabbing athlete, or a seasoned pro training at the highest levels of competition.

- ① **Digital Display:** Calories-Heart Rate( Blue tooth with heart rate Monitor)- Distance - Time - Odometer interval Training.
- ② Heavy Duty Steel Frame eliminates side-to-side movement.
- ③ 25" diameter Steel Fan.
- ④ Hybrid seat with multi-adjustment options.
- ⑤ Industrial powder coating for durability.
- ⑥ Reinforced pedals and crank
- ⑦ 10 sealed cartridge bearings, utilized in every pivot.

# D14

## Exercise Bike



- ① Pedal installation using Msing Mohs taper, with more closely, not easy to be damaged;
- ② Drive Mode Multiwedge Belt Scheme;
- ③ All use 19.5kg(43lb) external heavier flywheel; Increasing the weight of the flywheel outer ring increases the inertia, helps the bicycle to achieve a smooth movement, providing an experience that is closer to outdoor cycling than any other exercise biker;
- ④ Aerodynamics and round design is conducive to perspiration, and easy to clean and maintain. All the aluminum adjustable parts and the post-stabilizer can ensure rust-proof parts;
- ⑤ Large size steel frame is better to make sure the overall corrosion resistance, appearance and stiffness can be improved; it with front, rear handle adjustment and corrosion resistance of the aluminum stabilizer.
- ⑥ Device size and weight:  
Long + width + height: 1310\*535\*1275mm  
Weight: 61 KG

# D15

## Magnetic Resistance Exercise Bike



### Character:

1.Magnetic resistance adjustment dynamic bicycle, belt antiskid technology,Pidaichuangong supersilent, belt loose need not be removed Loading can be adjusted;

2.Brake pads do not contact the flywheel, arbitrary adjustment of resistance,smooth silky,infinite strength,to bring you unprecedented riding experience.

3.Free adjustment without limit resistance, always find the right resistance point for you.

### Other Character:

- ① Lifetime Maintenance-free, no need to replace the brake pads.
- ② Handles and cushions can be adjusted back and forth,up and down, to meet users of different heights and different riding modes. The adjustment of each part is equipped with calibration tips.
- ③ The handle and adjustment parts of cushion are made of aluminum alloy material to prevent rust.
- ④ Leather cushions use high elasticity, high density foam, wear resistance,soft texture, reduce the pain caused by long-term sitting.
- ⑤ N.W: 61.5KG, Overall more solid, safer.
- ⑥ Product Size: L\*W\*H: 1310\*535\*1275mm



# D16

## Magnetic Resistance Exercise Bike

- 1.The pedal is installed with Morse taper, which is more closely matched and not easy to be damaged
- 2.Commercial grade pure aluminum rear flywheel, high-speed operation without drifting
- 3.Oversized steel frame, with better overall corrosion resistance
- 4.Aerodynamics and circular design
- 5.Stepless magnetic control regulation

Product weight: 48.5kg

Floor area: 1190 (L) \*590 (W) \*1000 (H)

Tube type: flat oval tube 120\*40\*2.5t, flat oval tube 100\*50\*2.5t

# Cardio Series





### D01

#### Exercise Bike

Size:1120\*500\*1120mm

Machine Weight:60kg



### D07

#### Lesmill Exercise Bike

Size:1030\*580\*1140mm

Machine Weight:68kg



### D08

#### Lesmill Exercise Bike

Size:1050\*580\*1140mm

Machine Weight:70kg



### CC10

#### Upright Bike

Size:1110\*560\*1480mm

Machine Weight:65kg



### CC11

#### Recumbent Bike

Size:1600\*620\*1280mm

Machine Weight:80kg



### CC03

#### Upright Bike

Size:1090\*600\*1480mm

Machine Weight:45kg



### CC04

#### Recumbent Bike

Size:1090\*600\*1480mm

Machine Weight:57.3kg



### CC01

#### Stepper

Size:1250\*760\*1600mm

Machine Weight:66kg



### B06

**Elliptical**

Size:2100\*760\*1820mm

Machine Weight:100kg



### B03

**Elliptical**

Size:2070\*780\*1690mm

Machine Weight:81.7kg



### W4

**Foldable Wooden  
Water Rower**

Size:2050\*520\*560mm

Machine Weight:28kg



### W2

**Commercial Wooden  
Water Rower**

Size:2340\*520\*950mm

Machine Weight:40kg



### CC08

**Air Rower**

Size:2440\*610\*360mm

Machine Weight:27kg



### X005

**Skiing Machine**

Size:1300\*600\*2140mm

Machine Weight:38kg



### CC14

**Air Resistance Bike**

Size:1100\*550\*1150mm

Machine Weight:75kg



### TXD180

**AB Coaster**

Size:1515\*680\*1435mm

Machine Weight:60kg



**X001**

**Knee Lifting Rack**

Size:1600\*1200\*300mm

Machine Weight:50kg/60kg



**CC13**

**Tank Sled**

Size:1130\*750\*1070mm

Machine Weight:120kg



**C51**

**Super Tire**

Size:1210\*680\*1125mm

Machine Weight:40kg



**W10**

**Wind Resistance Rowing Machine**

Size:2000\*500\*650mm

Machine Weight:73kg



**D19**

**Gommercial Gym Bike**

Size:1088\*560\*1300mm

Machine Weight:60kg



**CC22**

**Pilates Set**



**CC21**

**Wooden Mechanical Treadmill**

Size:1800\*750\*600mm

Machine Weight:123kg



**D22**

**Air Resistance Bike**

Size:1293\*592\*1229mm

Machine Weight:49kg

# SP Series





**SP01**

**Super Vertical Chest Press**

Size:1905\*1395\*1620mm

Machine Weight:238kg



**SP02**

**Super Inclined Chest Press**

Size:1845\*1445\*1860mm

Machine Weight:220kg



**SP03**

**Super Declined Chest Press**

Size:1840\*1395\*1620mm

Machine Weight:218kg



**SP04**

**Super Horizontal Bench Press**

Size:2145\*1400\*1620mm

Machine Weight:229kg



**SP05**

**Super Inclined Bench Press**

Size:2420\*1395\*1620mm

Machine Weight:242.5kg



**SP06**

**Super Middle Chest Flight Machine**

Size:2080\*1845\*1620mm

Machine Weight:217kg



**SP07**

**Super Upper Chest Flight Machine**

Size:2050\*1435\*1620mm

Machine Weight:197kg



**SP08**

**Super Lower Chest Flight Machine**

Size:2475\*1400\*1620mm

Machine Weight:239kg



### SP09

#### Super Horizontal Multi Press

Size:2230\*1395\*1620mm

Machine Weight:216.5kg



### SP10

#### Dips Press Dual System

Size:1720\*1500\*1080mm

Machine Weight:165kg



### SP11

#### Dips Press

Size:1645\*1500\*1075mm

Machine Weight:153.5kg



### SP12

#### Super Pullover Machine

Size:2200\*1400\*1620mm

Machine Weight:286kg



### SP13

#### Pullover Machine

Size:1810\*1370\*1620mm

Machine Weight:286kg



### SP14

#### Super Lat Machine Convergent

Size:2075\*1445\*1895mm

Machine Weight:227.5kg



### SP15

#### Super Lat Pulldown Circular

Size:1530\*1645\*2265mm

Machine Weight:253kg



### SP16

#### Super High Row

Size:2165\*1445\*2160mm

Machine Weight:77.5kg



**SP17**

**Super Power Row**  
 Size:1565\*1445\*1860mm  
 Machine Weight:268kg



**SP18**

**Super Low Row**  
 Size:1555\*1445\*1860mm  
 Machine Weight:256.5kg



**SP19**

**Super Rowing**  
 Size:1830\*1400\*1620mm  
 Machine Weight:268kg



**SP20**

**Super Rowing Circular**  
 Size:2090\*1400\*1620mm  
 Machine Weight:244kg



**SP21**

**T-bar Row**  
 Size:1530\*1365\*1620mm  
 Machine Weight:225kg



**SP22**

**Super Dorsy Bar**  
 Size:1830\*1345\*1620mm  
 Machine Weight:137kg



**SP23**

**Front Dorsy Bar**  
 Size:1475\*1395\*1620mm  
 Machine Weight:186.5kg



**SP24**

**Super Shrug Machine**  
 Size:1750\*1400\*1620mm  
 Machine Weight:221.5kg



### SP25

#### Super Deltoid Press

Size:2055\*1395\*1620mm

Machine Weight:207kg



### SP26

#### Lateral Deltoids

Size:1325\*1460\*1620mm

Machine Weight:158kg



### SP27

#### Back Deltoids

Size:1550\*1390\*1620mm

Machine Weight:141kg



### SP28

#### Super French Press Machine

Size:1955\*1400\*1620mm

Machine Weight:256kg



### SP29

#### Alternate Triceps Machine

Size:1510\*1855\*1410mm

Machine Weight:174kg



### SP30

#### Triceps Machine

Size:1460\*1645\*1365mm

Machine Weight:137kg



### SP31

#### Alternate Curling Machine

Size:1215\*1800\*1060mm

Machine Weight:138.5kg



### SP32

#### Curling Machine

Size:1215\*1600\*1065mm

Machine Weight:129.5kg



**SP33**

**Three Angles  
Biceps Machine**

Size:1215\*1915\*1310mm

Machine Weight:244kg



**SP34**

**Super Leg  
Press Bridge**

Size:2605\*1605\*1630mm

Machine Weight:322kg



**SP35**

**Super Horizontal Leg  
Press Dual System**

Size:2760\*1595\*1680mm

Machine Weight:286kg



**SP36**

**Super Leg Press 45°**

Size:2450\*1770\*1620mm

Machine Weight:379kg



**SP37**

**Super Leg Press 45°  
Dual System**

Size:2475\*1790\*1645mm

Machine Weight:405kg



**SP38**

**Super Vertical  
Leg Press**

Size:2055\*2210\*2055mm

Machine Weight:346kg



**SP39**

**Vertical Leg Press**

Size:2040\*2195\*2055mm

Machine Weight:326kg



**SP40**

**Super Squat Machine**

Size:1885\*1395\*1620mm

Machine Weight:224kg



### SP41

#### Super Power Squat

Size:1980\*1495\*1620mm

Machine Weight:255kg



### SP42

#### Super Pendulum Squat

Size:2020\*1860\*1445mm

Machine Weight:280kg



### SP43

#### Belt Squat

Size:1650\*1395\*1620mm

Machine Weight:276kg



### SP44

#### Super Hack Squat

Size:2280\*1345\*1620mm

Machine Weight:287kg



### SP45

#### Super Calf Hack

Size:2135\*1345\*1620mm

Machine Weight:279kg



### SP46

#### Power Runner

Size:2180\*1400\*1425mm

Machine Weight:235kg



### SP47

#### Hip Thrust

Size:2080\*1425\*1390mm

Machine Weight:274kg



### SP48

#### Standing Abductor

Size:1950\*1400\*1620mm

Machine Weight:289kg



**SP49**

**Alternate Leg Extension**

Size:1325\*1695\*1505mm

Machine Weight:189kg



**SP50**

**Leg Extension**

Size:1326\*1420\*1505mm

Machine Weight:179kg



**SP51**

**Alternate Leg Curling**

Size:1675\*1635\*895mm

Machine Weight:182kg



**SP52**

**Leg Curling**

Size:1685\*1360\*845mm

Machine Weight:136kg



**SP53**

**Seated Leg Curling**

Size:1440\*1420\*1505mm

Machine Weight:168kg



**SP54**

**Kneeling Leg Curling**

Size:1215\*1915\*1570mm

Machine Weight:207.5kg



**SP55**

**Reverse Hyper Extension**

Size:1370\*1275\*1500mm

Machine Weight:163kg



**SP56**

**Super Seated Calf**

Size:1535\*1275\*1270mm

Machine Weight:188kg



### SP57

#### Donkey Calf

Size:1920\*1360\*1620mm

Machine Weight:197kg



### SP58

#### Super Peck Back

Size:1605\*1450\*1930mm

Machine Weight:234kg



### SP59

#### Viking Press and Calf

Size:1885\*1445\*1900mm

Machine Weight:258kg



### SP60

#### Olympic Smith Machine Counterbalanced

Size:1460\*2205\*2475mm

Machine Weight:220kg



### SP61

#### Olympic Half Rack

Size:1535\*1545\*2520mm

Machine Weight:178kg



### SP62

#### Olympic Power Rack

Size:1710\*1545\*2520mm

Machine Weight:205.5kg



**SP63**

**Military Bench**

Size:1425\*1595\*1855mm

Machine Weight:178kg



**SP64**

**Preacher Curl Bench**

Size:1560\*1595\*965mm

Machine Weight:79kg



**SP65**

**Curl Rack Bench**

Size:880\*1250\*970mm

Machine Weight:55kg



**SP66**

**Seal Row Bench**

Size:1395\*1155\*905mm

Machine Weight:85kg



**SP67**

**Tower Chest Push Trainer**

Size:2235\*1745\*1615mm

Machine Weight:245kg



**SP68**

**Tower Shoulder Lifting Trainer**

Size:2100\*1955\*2215mm

Machine Weight:242kg

# FM Series





**FM01**

**Seated Chest Press**

Size:1520\*1215\*1640mm

Machine Weight:195.5kg

**FM02**

**Rear Delt/  
Pec Fly**

Size:865\*1260\*2080mm

Machine Weight:187.5kg

**FM03**

**Pectoral Machine**

Size:1135\*1380\*2080mm

Machine Weight:196kg

**FM04**

**Seated Shoulder Press**

Size:1590\*1570\*1640mm

Machine Weight:193kg

**FM05**

**Lateral Raise**

Size:925\*1010\*1640mm

Machine Weight:181.5kg



**FM06**

**Pulldown**

Size:1300\*1565\*1930mm

Machine Weight:193kg

**FM07**

**Lat Pulldown**

Size:1000\*1435\*2260mm

Machine Weight:187kg

**FM08**

**Seated Rowing**

Size:870\*1290\*1920mm

Machine Weight:187kg

**FM09**

**Biceps Curl**

Size:1120\*1265\*1640mm

Machine Weight:178.5kg

**FM10**

**Seated Triceps**

Size:1120\*1265\*1640mm

Machine Weight:183.5kg



### FM11

**Dip/Chin Assist**

Size:1220\*1445\*2320mm

Machine Weight:248kg



### FM12

**Leg Press**

Size:1060\*1960\*1640mm

Machine Weight:248kg



### FM13

**Leg Extension**

Size:1065\*1190\*1640mm

Machine Weight:201kg



### FM14

**Leg Curl**

Size:1010\*1410\*1640mm

Machine Weight:216kg



### FM15

**Prone Leg Curl**

Size:1070\*1740\*1640mm

Machine Weight:141kg



### FM16

**Abductor**

Size:580\*1450\*1640mm

Machine Weight:195.5kg



### FM17

**Adductor**

Size:580\*1450\*1640mm

Machine Weight:195kg



### FM18

**Standing Calf**

Size:1100\*1500\*1695mm

Machine Weight:192.5kg



### FM19

**Calf Machine**

Size:1060\*1770\*1640mm

Machine Weight:188.5kg



### FM20

**Multi-hip**

Size:1100\*1680\*1760mm

Machine Weight:238.5kg



**FM21**

**Back Extension**

Size:1020\*1170\*1640mm

Machine Weight:194kg



**FM22**

**Abdominal Crunch**

Size:940\*1620\*1640mm

Machine Weight:204kg



**FM23**

**Pull Down**

Size:2135\*865\*1800mm

Machine Weight:170kg



**FM25**

**Abductor / Adductor Trainer**

Size:1505\*635\*1640mm

Machine Weight:188.5kg



**FM85**

**Waist/Abdomen Trainer**

Size:1165\*1070\*1640mm

Machine Weight:200.5kg



**FM86**

**Biceps/Triceps**

Size:1030\*995\*1640mm

Machine Weight:200.5kg



**FM87**

**Seated Leg Curl/Extension**

Size:1445\*1095\*1640mm

Machine Weight:209kg



**FM88**

**Multi-direction Chest Push Trainer**

Size:2025\*1310\*1640mm

Machine Weight:207kg



**FM89**

**Pull Down/ Long Pull**

Size:2285\*1130\*2280mm

Machine Weight:210kg



**FM90**

**Prone Leg Curl/ Seated Extension**

Size:1315\*1035\*1640mm

Machine Weight:221kg

# FS Series





**FS01**

**Prone Leg Curl**

Size:1515\*1110\*1470mm

Machine Weight:211.5kg



**FS02**

**Leg Extension**

Size:1325\*1255\*1470mm

Machine Weight:223kg



**FS03**

**Leg Press**

Size:1970\*1125\*1470mm

Machine Weight:251.5kg



**FS05**

**Lateral Raise**

Size:1270\*1245\*1470mm

Machine Weight:196.5kg



**FS06**

**Shoulder Press**

Size:1230\*1345\*1470mm

Machine Weight:215kg



**FS07**

**Rear Delt/Pec Fly**

Size:1050\*1510\*2095mm

Machine Weight:245kg



**FS08**

**Vertical Press**

Size:1430\*1415\*1470mm

Machine Weight:216kg



**FS09**

**Dip/Chin Assist**

Size:1410\*1030\*2430mm

Machine Weight:293kg



### FS10

**Split Push Chest Trainer**

Size:1545\*1290\*1860mm

Machine Weight:226kg



### FS18

**Rotary Torso**

Size:1270\*1355\*1470mm

Machine Weight:182.5kg



### FS19

**Abdominal Machine**

Size:1350\*1290\*1470mm

Machine Weight:194kg



### FS20

**Split Shoulder Lifting Trainer**

Size:1300\*1490\*1470mm

Machine Weight:211.5kg



### FS23

**Leg Curl**

Size:1485\*1255\*1470mm

Machine Weight:210kg



### FS24

**Glute Isolator**

Size:1360\*980\*1470mm

Machine Weight:191kg



### FS25

**Abductor/ Adductor Trainer**

Size:1510\*750\*1470mm

Machine Weight:200.5kg



### FS26

**Seated Dip**

Size:1175\*1215\*1470mm

Machine Weight:204.5kg



**FS28**

**45 Degree Triceps Extension**

Size:1130\*1255\*1470mm

Machine Weight:183kg



**FS29**

**Split High Pull Trainer**

Size:1550\*1200\*2055mm

Machine Weight:232.5kg



**FS30**

**45 Degree Camber Curl**

Size:1255\*1250\*1470mm

Machine Weight:181kg



**FS31**

**Back Extension**

Size:1260\*1085\*1470mm

Machine Weight:206.5kg



**FS33**

**Long Pull**

Size:1455\*1175\*1470mm

Machine Weight:177kg



**FS34**

**Seated Row**

Size:1270\*1325\*1470mm

Machine Weight:216kg



**FS35**

**Pulldown**

Size:1475\*1700\*1955mm

Machine Weight:254.5kg



**FS93**

**Seated Calf**

Size:1330\*1085\*1470mm

Machine Weight:179.5kg

# FH Series



## Instructional Placard

Clear and concise muscle target makes it easier for trainers to know and learn



## Adjustments

Humanization design adjustment. Trainers can adjust the position according to personal body condition



## Upholstery

PU leather cushion, air permeability, sweating, comfort and anti-skid



## 6mm Thick Steel Cable

Fitness equipment uses 6mm thick steel cable, which is more durable and safer

**FH01****Prone Leg Curl**

Size:1510\*1075\*1550mm

Machine Weight:234.5kg

Weight Stack:100kg

**FH02****Leg Extension**

Size:1325\*1230\*1550mm

Machine Weight:245.5kg

Weight Stack:100kg

**FH03****Leg Press**

Size:1960\*1090\*1550mm

Machine Weight:287.5kg

Weight Stack:115kg

**FH05****Lateral Raise**

Size:1260\*1180\*1550mm

Machine Weight:219.5kg

Weight Stack:70kg

**FH06****Shoulder Press**

Size:1325\*1300\*1550mm

Machine Weight:236.5kg

Weight Stack:100kg

**FH07****Rear Delt/Pec Fly**

Size:1490\*1075\*2190mm

Machine Weight:268.5kg

Weight Stack:100kg

**FH08****Vertical Press**

Size:1425\*1395\*1550mm

Machine Weight:238.5kg

Weight Stack:100kg

**FH09****Dip/Chin Assist**

Size:1685\*1120\*2425mm

Machine Weight:329.5kg

Weight Stack:100kg



### FH10

#### Split Push Chest Trainer

Size:1545\*1285\*1860mm

Machine Weight:248.5kg

Weight Stack:100kg



### FH16

#### Cable Crossover

Size:4265\*720\*2365mm

Machine Weight:325kg

Weight Stack:70kg\*2

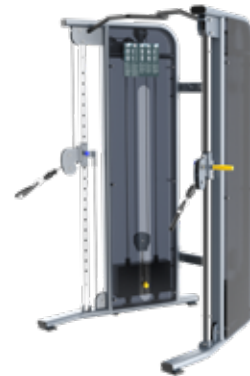

### FH17

#### FTS Glide

Size:1525\*1245\*2170mm

Machine Weight:396kg

Weight Stack:70\*2kg



### FH18

#### Rotary Torso

Size:1350\*1335\*1550mm

Machine Weight:203.5kg

Weight Stack:70kg



### FH19

#### Abdominal Machine

Size:1330\*1290\*1550mm

Machine Weight:250kg

Weight Stack:70kg



### FH20

#### Split Shoulder Lifting Trainer

Size:1480\*1270\*1550mm

Machine Weight:232kg

Weight Stack:100kg



### FH23

#### Seated Leg Curl

Size:1600\*1235\*1550mm

Machine Weight:231kg

Weight Stack:70kg



### FH24

#### Glute Isolator

Size:1350\*950\*1550mm

Machine Weight:213kg

Weight Stack:70kg



**FH25**

**Abductor/  
Adductor Trainer**

Size:1480\*825\*1550mm

Machine Weight:223kg

Weight Stack:70kg



**FH26**

**Seated Dip**

Size:1285\*1150\*1550mm

Machine Weight:228kg

Weight Stack:85kg



**FH28**

**Triceps Extension**

Size:1235\*1180\*1550mm

Machine Weight:205kg

Weight Stack:70kg



**FH29**

**Split High Pull Trainer**

Size:1540\*1180\*2055mm

Machine Weight:188kg

Weight Stack:100kg



**FH30**

**45 Degree Camber Curl**

Size:1250\*1230\*1550mm

Machine Weight:203kg

Weight Stack:70kg



**FH31**

**Back Extension**

Size:1335\*1060\*1550mm

Machine Weight:233.5kg

Weight Stack:100kg



**FH33**

**Seated Low Row**

Size:1455\*1155\*1820mm

Machine Weight:243kg

Weight Stack:85kg



**FH34**

**Seated Row**

Size:1305\*1265\*1550mm

Machine Weight:233kg

Weight Stack:100kg



### FH35

#### Pulldown

Size:1700\*1450\*1955mm

Machine Weight:267kg

Weight Stack:100kg



### FH93

#### Seated Calf

Size:1330\*1140\*1550mm

Machine Weight:201.5kg

Weight Stack:70kg



### FH85

#### Abdominal/Back Extension

Size:1220\*1155\*1550mm

Machine Weight:216.5kg

Weight Stack:70kg



### FH85B

#### Abdominal/Back Extension

Size:1335\*1100\*1550mm

Machine Weight:216.5kg

Weight Stack:70kg



### FH86

#### Biceps/Triceps

Size:1590\*1320\*2230mm

Machine Weight:215.5kg

Weight Stack:70kg



### FH86B

#### Biceps/Triceps

Size:1300\*1295\*1550mm

Machine Weight:215.5kg

Weight Stack:70kg



### FH87

#### Leg Extension/Curl

Size:1460\*1245\*1550mm

Machine Weight:259.5kg

Weight Stack:70kg



### FH87B

#### Leg Extension/Curl

Size:1340\*1245\*1550mm

Machine Weight:259.5kg

Weight Stack:70kg



### FH88

**Chest/Shoulder Press**

Size:2235\*1500\*1550mm

Machine Weight:264kg

Weight Stack:70kg



### FH89

**Pull Down/Long Pull**

Size:1610\*1280\*2145mm

Machine Weight:268kg

Weight Stack:70kg



### FH89B

**Pull Down/Long Pull**

Size:2110\*1100\*2225mm

Machine Weight:268kg

Weight Stack:70kg



# MND-MA Series

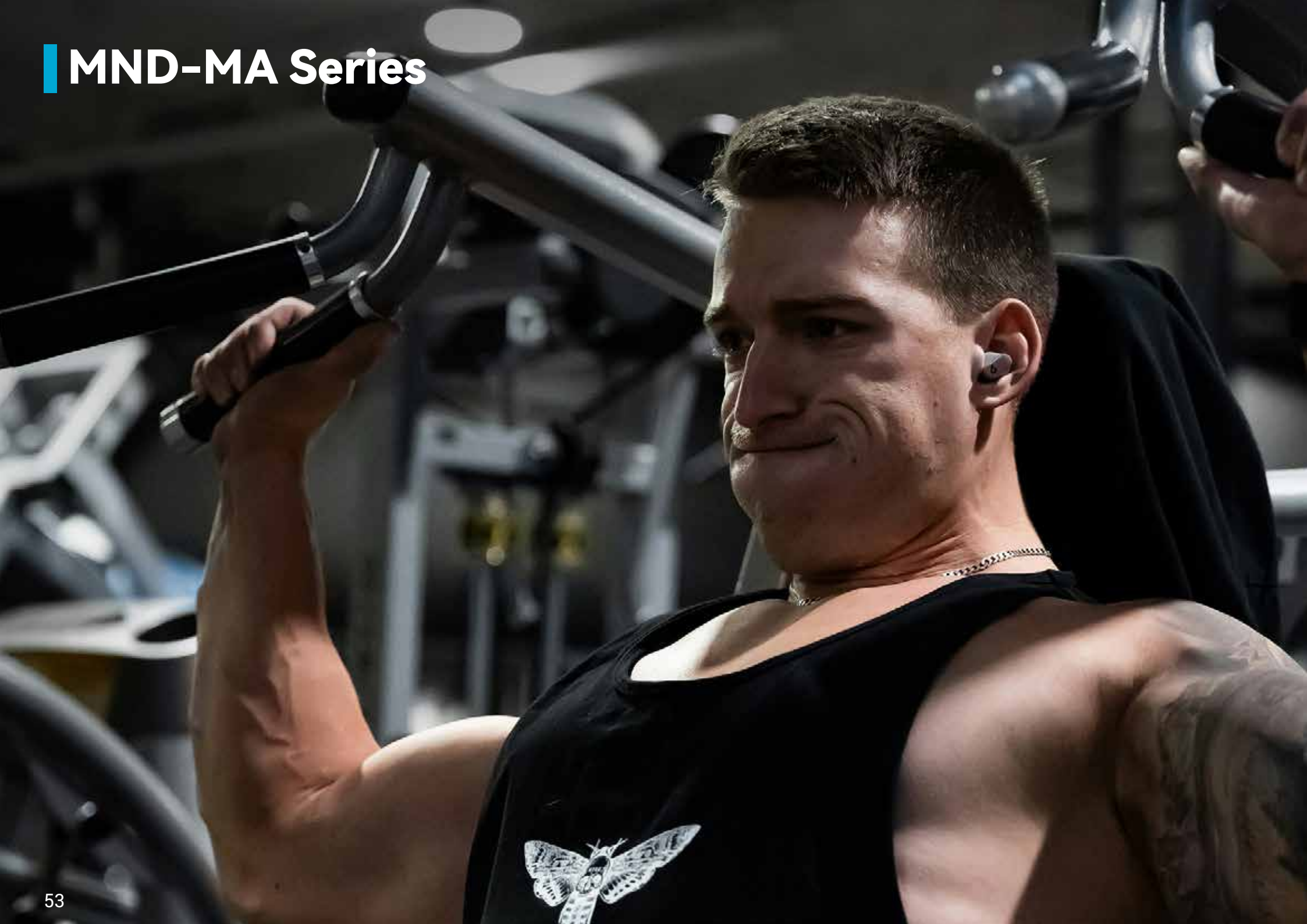



**MA01**

**Kick Back**

Size:1735\*1660\*1246mm

Machine Weight:205.5kg

Weight Stack:70kg



**MA02**

**Standing Hip Thrust**

Size:1735\*1660\*1247mm

Machine Weight:209kg

Weight Stack:70kg



**MA03**

**Back Extension**

Size:1735\*1660\*1248mm

Machine Weight:205.5kg

Weight Stack:70kg



**MA04**

**Hip-thrusting**

Size:1735\*1660\*1249mm

Machine Weight:254kg

Weight Stack:70kg



**MA05**

**Standing Abductor**

Size:1735\*1660\*1250mm

Machine Weight:243kg

Weight Stack:70kg



**MA06**

**Gluteus Maximus Trainer**

Size:1955\*1310\*1550mm

Machine Weight:258kg

Weight Stack:70kg

# FB Series





**FB01**

**Prone Leg Curl**

Size:1095\*1540\*1500mm

Machine Weight:209.5kg



**FB02**

**Leg Extension**

Size:1245\*1365\*1500mm

Machine Weight:220kg



**FB03**

**Leg Press**

Size:1120\*1985\*1500mm

Machine Weight:261.5kg



**FB05**

**Lateral Raise**

Size:1240\*1245\*1500mm

Machine Weight:192kg



**FB06**

**Shoulder Press**

Size:1230\*1345\*1500mm

Machine Weight:207.5kg



**FB07**

**Rear Delt/Pec Fly**

Size:1050\*1510\*2095mm

Machine Weight:246kg



**FB08**

**Vertical Press**

Size:1390\*1420\*1500mm

Machine Weight:210.5kg



**FB09**

**Dip/Chin Assist**

Size:1025\*1710\*2460mm

Machine Weight:304.5kg



**FB10**  
**Split Push Chest Trainer**  
Size:1290\*1540\*1860mm  
Machine Weight:220kg



**FB18**  
**Rotary Torso**  
Size:1270\*1355\*1500mm  
Machine Weight:176kg



**FB19**  
**Abdominal Machine**  
Size:1350\*1290\*1500mm  
Machine Weight:188kg



**FB20**  
**Split Shoulder Lifting Trainer**  
Size:1300\*1490\*1500mm  
Machine Weight:203kg



**FB23**  
**Leg Curl**  
Size:1635\*1245\*1500mm  
Machine Weight:230kg



**FB24**  
**Glute Isolator**  
Size:1360\*980\*1500mm  
Machine Weight:189.5kg



**FB25**  
**Abductor/ Adductor Trainer**  
Size:1480\*825\*1500mm  
Machine Weight:194kg



**FB26**  
**Seated Dip**  
Size:1175\*1205\*1500mm  
Machine Weight:202.5kg



**FB29**

**Split High Pull Trainer**  
 Size:1205\*1470\*2055mm  
 Machine Weight:228.5kg



**FB30**

**45 Degree Camber Curl**  
 Size:1260\*1250\*1500mm  
 Machine Weight:175kg



**FB33**

**Long Pull**  
 Size:1165\*1470\*1500mm  
 Machine Weight:180kg



**FB34**

**Seated Row**  
 Size:1295\*1335\*1500mm  
 Machine Weight:206kg



**FB35**

**Pulldown**  
 Size:1485\*1680\*1870mm  
 Machine Weight:247.5kg

# FF Series



## Instructional Placard

Clear and concise muscle target makes it easier for trainers to know and learn.



## Adjustments

Humanization design adjustment. Trainers can adjust the position according to personal body condition



## Footboard

Stainless Steel Wire Drawing Hollow Pedal, Anti-Skid and Wear-Resistant, Looks Elegant



## Upholstery

PU leather cushion, air permeability, sweating, comfort and anti-skid

**FF01****Prone Leg Curl**

Size:1515\*1095\*1500mm

Machine Weight:211.5kg

Weight Stack:100kg

**FF02****Leg Extension**

Size:1315\*1255\*1500mm

Machine Weight:223kg

Weight Stack:100kg

**FF03****Leg Press**

Size:1970\*1125\*1500mm

Machine Weight:251.5kg

Weight Stack:115kg

**FF05****Lateral Raise**

Size:1270\*1260\*1500mm

Machine Weight:196.5kg

Weight Stack:70kg

**FF06****Shoulder Press**

Size:1225\*1345\*1500mm

Machine Weight:215kg

Weight Stack:100kg

**FF07****Rear Delt/Pec Fly**

Size:1030\*965\*2095mm

Machine Weight:245kg

Weight Stack:100kg

**FF08****Vertical Press**

Size:1430\*1415\*1500mm

Machine Weight:216kg

Weight Stack:100kg

**FF09****Dip/Chin Assist**

Size:1410\*1025\*2435mm

Machine Weight:293kg

Weight Stack:100kg



### FF10

#### Split Push Chest Trainer

Size:1545\*1290\*1860mm

Machine Weight:226kg

Weight Stack:100kg



### FF16

#### Cable Crossover

Size:4512\*940\*2360mm

Machine Weight:317kg

Weight Stack:70\*2kg



### FF17

#### Functional Trainer

Size:1525\*1245\*2170mm

Machine Weight:295kg

Weight Stack:70\*2kg



### FF18

#### Rotary Torso

Size:1355\*1270\*1500mm

Machine Weight:182.5kg

Weight Stack:70kg



### FF19

#### Abdominal Machine

Size:1340\*1290\*1500mm

Machine Weight:194kg

Weight Stack:70kg



### FF20

#### Split Shoulder Lifting Trainer

Size:1490\*1270\*1500mm

Machine Weight:211.5kg

Weight Stack:100kg



### FF23

#### Leg Curl

Size:1485\*1255\*1500mm

Machine Weight:210kg

Weight Stack:70kg



### FF24

#### Glute Isolator

Size:1360\*980\*1500mm

Machine Weight:191kg

Weight Stack:70kg

**FF25****Abductor/Adductor**

Size:1510\*750\*1500mm

Machine Weight:200.5kg

Weight Stack:70kg

**FF26****Seated Dip**

Size:1205\*1150\*1500mm

Machine Weight:204.5kg

Weight Stack:85kg

**FF28****45 Degree Triceps Extension**

Size:1130\*1255\*1500mm

Machine Weight:195kg

Weight Stack:70kg

**FF29****Split High Pull Trainer**

Size:1550\*1200\*2055mm

Machine Weight:232.5kg

Weight Stack:100kg

**FF30****45 Degree Camber Curl**

Size:1255\*1250\*1500mm

Machine Weight:181kg

Weight Stack:70kg

**FF31****Back Extension**

Size:1260\*1085\*1500mm

Machine Weight:206.5kg

Weight Stack:100kg

**FF33****Long Pull**

Size:1455\*1175\*1500mm

Machine Weight:177kg

Weight Stack:85kg

**FF34****Seated Row**

Size:1325\*1270\*1500mm

Machine Weight:216kg

Weight Stack:100kg



### FF35

#### Pulldown

Size:1700\*1475\*1955mm

Machine Weight:254.5kg

Weight Stack:100kg



### FF93

#### Seated Calf

Size:1330\*1085\*1500mm

Machine Weight:179.5kg

Weight Stack:70kg



### FF85

#### Waist/Abdomen Trainer

Size:1120\*1155\*1500mm

Machine Weight:185.5kg



### FF86

#### Biceps/Triceps

Size:1315\*1185\*1500mm

Machine Weight:193.5kg



### FF87

#### Seated Leg Curl/Extension

Size:1255\*1360\*1500mm

Machine Weight:214.5kg



### FF88

#### Chest/Shoulder Press

Size:1515\*2235\*1500mm

Machine Weight:261kg



### FF89

#### Pull Down/ Long Pull

Size:2130\*1230\*2225mm

Machine Weight:215kg

Weight Stack:70kg



### FF90

#### Prone Leg Curl/ Seated Extension

Size:1155\*1530\*1500mm

Machine Weight:206.5kg



### FF94

#### Side Flat Lifting Chest Trainer

Size:1465\*865\*2005mm

Machine Weight:290kg



**FF36**

**Flat Bench**

Size:1280\*740\*380mm

Machine Weight:19.5kg



**FF37**

**Adjustable Decline Bench**

Size:1630\*740\*1075mm

Machine Weight:39kg



**FF38**

**Multi-Purpose Bench**

Size:1155\*730\*950mm

Machine Weight:22.5kg



**FF39**

**Super Bench**

Size:1330\*740\*515mm

Machine Weight:32kg



**FF41**

**Olympic Decline Bench**

Size:2235\*1785\*1270mm

Machine Weight:77kg



**FF41B**

**Olympic Decline Bench**

Size:2225\*1705\*1270mm

Machine Weight:77kg



**FF42**

**Olympic Incline Bench**

Size:1940\*1785\*1420mm

Machine Weight:76.5kg



**FF42B**

**Olympic Incline Bench**

Size:1925\*1705\*1415mm

Machine Weight:92kg



### FF43

#### Olympic Flat Bench

Size:1740\*1785\*1280mm

Machine Weight:65kg



### FF43B

#### Olympic Flat Bench

Size:1725\*1705\*1270mm

Machine Weight:82kg



### FF44

#### Seated Preacher Curl

Size:925\*935\*900mm

Machine Weight:40.5kg



### FF45

#### Roman Chair

Size:1100\*750\*790mm

Machine Weight:43kg



### FF46

#### Multi Degree Olympic Bench

Size:2045\*1250\*1590mm

Machine Weight:53.5kg



### FF47

#### Vertical Knee Up

Size:1140\*785\*1590mm

Machine Weight:73.5kg



### FF48

#### Power Cage

Size:1315\*1560\*2290mm

Machine Weight:106kg



### FF49

#### Two Layer Dumbbell Rack

Size:2230\*750\*755mm

Machine Weight:64kg



**FF50**  
**Squat Rack**  
 Size:1690\*1640\*1840mm  
 Machine Weight:91.5kg



**FF51**  
**Olympic Seated Bench**  
 Size:1640\*1320\*1770mm  
 Machine Weight:107kg



**FF53**  
**Handle Rack**  
 Size:900\*710\*1060mm  
 Machine Weight:48kg



**FF54**  
**Weight Plate Tree**  
 Size:600\*620\*1315mm  
 Machine Weight:23kg

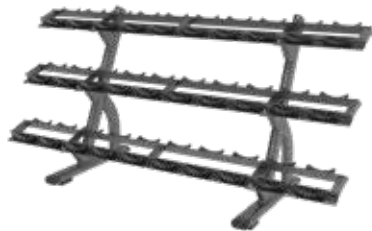

**FF72**  
**3 Layers Dumbbell Rack**  
 Size:2230\*780\*1070mm  
 Machine Weight:89kg



**FF55**  
**Barbell Rack**  
 Size:900\*795\*1500mm  
 Machine Weight:61kg



**FF63**  
**Smith Machine**  
 Size:2175\*1310\*2320mm  
 Machine Weight:164.5kg

# AN Series



Round Steel Tube Wrapped By Rubber Handle, Good grasp feeling on muscle training



The weight can be increased or decreased according to user's own situation, the magnetic pull pin has good safety protection effect.



High Intensity Nylon Pulley, Elegant and Durable



Clear and concise muscle Instruction picture help the user to know how to use the machine



### AN04

#### Lat Pulldown

Size:1240\*1210\*2330mm

Machine Weight:224kg

Weight Stack:100kg



### AN05

#### Pectoral Machine

Size:1350\*1440\*1500mm

Machine Weight:275kg

Weight Stack:100kg



### AN06

#### Seated Horizontal Pully

Size:1790\*1345\*1830mm

Machine Weight:214kg

Weight Stack:100kg



### AN09

#### Inner Thigh Adductor

Size:1185\*1400\*1500mm

Machine Weight:280kg

Weight Stack:70kg



### AN10

#### Outer Thigh Abductor

Size:1345\*860\*1500mm

Machine Weight:280kg

Weight Stack:70kg



### AN14

#### Cable Crossover

Size:3800\*685\*2395mm

Machine Weight:328kg

Weight Stack:70kg\*2



### AN15

#### Triceps Extension

Size:1045\*1480\*1480mm

Machine Weight:182kg

Weight Stack:70kg



### AN16

#### Leg Press

Size:1985\*1240\*1815mm

Machine Weight:445kg

Weight Stack:100kg



### AN18

#### Multi Hip

Size:1150\*1215\*1490mm

Machine Weight:290kg

Weight Stack:100kg



### AN19

#### Lower Back

Size:1095\*1275\*1495mm

Machine Weight:255kg

Weight Stack:70kg



### AN20

#### Chest Press

Size:1400\*1345\*1665mm

Machine Weight:252.5kg

Weight Stack:100kg



### AN21

#### Pull Down

Size:1395\*1395\*1790mm

Machine Weight:262.5kg

Weight Stack:100kg



### AN22

#### Total Abdominal

Size:1470\*1610\*2100mm

Machine Weight:227.5kg

Weight Stack:100kg



### AN23

#### Upper Limbs

Size:1625\*1440\*2670mm

Machine Weight:350kg

Weight Stack:115kg



### AN24

#### Seated Leg Curl

Size:1180\*1530\*1500mm

Machine Weight:235.5kg

Weight Stack:100kg



### AN25

#### Arm Curl

Size:1000\*1455\*1500mm

Machine Weight:179kg

Weight Stack:70kg



### AN26

#### Shoulder Press

Size:1415\*940\*1500mm

Machine Weight:232kg

Weight Stack:70kg



### AN27

#### Leg Extension

Size:1175\*1100\*1500mm

Machine Weight:232.5kg

Weight Stack:100kg



### AN30

#### Abdominal Machine

Size:1060\*1355\*1500mm

Machine Weight:255kg

Weight Stack:100kg



### AN32

#### Pull Down

Size:860\*1300\*1915mm

Machine Weight:300kg

Weight Stack:100kg



### AN33

#### Seated Row

Size:1025\*1195\*1500mm

Machine Weight:255kg

Weight Stack:100kg



### AN34

#### Delt Machine

Size:1155\*1285\*1500mm

Machine Weight:280kg

Weight Stack:100kg



### AN35

#### Rotary Torso

Size:1085\*1225\*1500mm

Machine Weight:270kg

Weight Stack:70kg



### AN36

#### Glute Isolator

Size:1200\*1335\*1810mm

Machine Weight:290kg

Weight Stack:70kg



### AN37

#### Horizontal Leg Curl

Size:1718\*1100\*1500mm

Machine Weight:265kg

Weight Stack:100kg



### AN38

#### Pearl Delt /Pec Fly

Size:855\*1165\*2100mm

Machine Weight:220.5kg

Weight Stack:100kg



### AN46

#### Biceps Curl

Size:1295\*1020\*1490mm

Machine Weight:164.5kg

Weight Stack:70kg



### AN47

#### Chest Incline

Size:1500\*1130\*1505mm

Machine Weight:300kg

Weight Stack:100kg



### AN48

#### Standing Calf

Size:1145\*1030\*1660mm

Machine Weight:220kg

Weight Stack:100kg



### AN49

#### Triceps Dip

Size:1245\*1160\*1480mm

Machine Weight:199kg

Weight Stack:70kg



### AN54

#### Functional Trainer

Size:2055\*1265\*2420mm

Machine Weight:344kg

Weight Stack:70kg\*2



### AN74

#### Standing Rear Delt

Size:1200\*900\*1855mm

Machine Weight:243kg

Weight Stack:70kg



### AN01

**Weight Plate Tree**  
Size:660\*740\*825mm  
Machine Weight:28kg



### AN02

**Dumbbell Rack**  
Size:2410\*560\*880mm  
Machine Weight:61kg



### AN03

**Barbell Rack**  
Size:885\*690\*1300mm  
Machine Weight:90kg



### AN07

**Adjustable Web Board**  
Size:1520\*665\*945mm  
Machine Weight:42.5kg



### AN08

**Flat Bench**  
Size:1185\*570\*550mm  
Machine Weight:35kg



### AN12

**Multi Adjustable Bench**  
Size:1215\*565\*480mm  
Machine Weight:31.5kg



### AN13

**Scott Bench**  
Size:1010\*800\*915mm  
Machine Weight:42kg



### AN17

**Smith Machine**  
Size:2200\*2070\*2500mm  
Machine Weight:233kg



### AN28

#### Vertical Bench

Size:1245\*1645\*1870mm

Machine Weight:74kg



### AN31

#### Roman Chair

Size:1295\*675\*790mm

Machine Weight:34kg



### AN73

#### Adjustable Roman Chair

Size:1400\*675\*950mm

Machine Weight:42kg



### AN40

#### Utility Bench

Size:1070\*630\*910mm

Machine Weight:23.5kg



### AN44

#### Decline Bench (Luxury)

Size:2225\*1620\*1360mm

Machine Weight:89.5kg



### AN50

#### Squat Rack

Size:1675\*1520\*1810mm

Machine Weight:98.5kg



### AN52

#### Olympic Flat Bench

Size:1625\*1855\*1290mm

Machine Weight:82.5kg



### AN55

#### Hack Squat

Size:2090\*1650\*1290mm

Machine Weight:170kg



### AN56

**Leg Press**

Size:2340\*1460\*1670mm

Machine Weight:230kg



### AN57

**Web Board**

Size:1795\*615\*950mm

Machine Weight:36kg



### AN58

**Vertical Knee Chin/Up**

Size:1500\*1305\*2310mm

Machine Weight:66.5kg



### AN59

**Incline Bench (Luxury)**

Size:2100\*1640\*1540mm

Machine Weight:106.5kg



### AN61

**Barbell Rack for 10pcs**

Size:1065\*870\*1480mm

Machine Weight:71.5kg

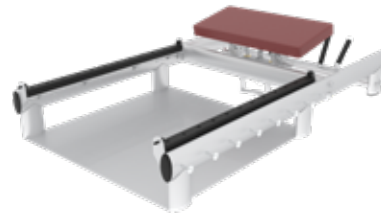

### AN65-(1)

**Hip Machine**

Size:1960\*1190\*460mm

Machine Weight:110kg



### AN65-(2)

**Hip Machine**

Size:1960\*1190\*460mm

Machine Weight:130kg



### AN70

**T Incline Rower Machine**

Size:2305\*830\*835mm

Machine Weight:58kg



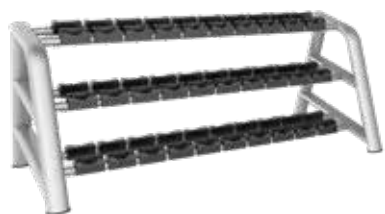

### AN72

**3 Layers Dumbbell Rack**

Size:2450\*950\*970mm

Machine Weight:85kg



### AN75

**Knee Up/Chin+Pull Up**

Size:1455\*1360\*2235mm

Machine Weight:208kg



### AN17A

**Customized Smith Machine**

Size:2200\*2450\*2490mm

Machine Weight:400kg

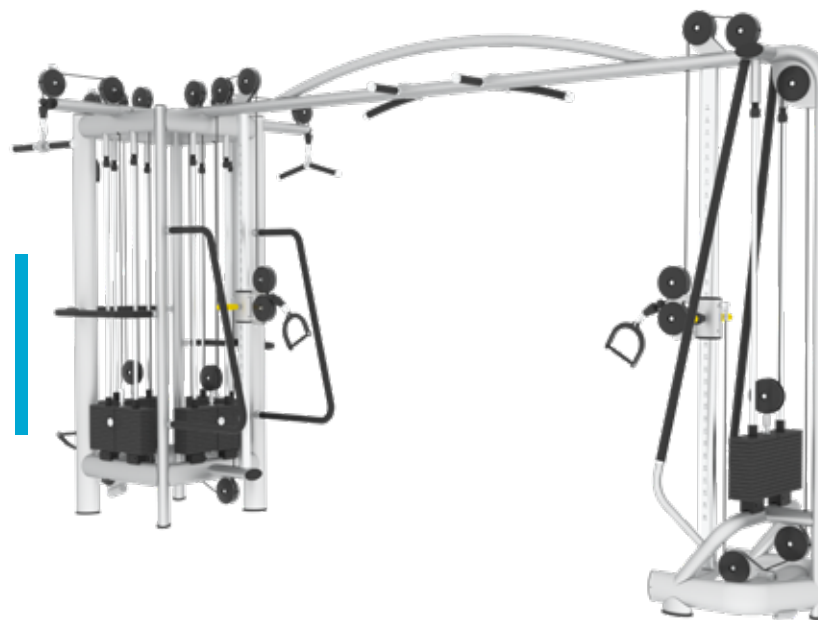

### AN41

**Crossover & Cable Jungle (5 stations)**

Size:4615\*1920\*2395mm

Machine Weight:680kg

Weight Stack:70kg\*4

100kg\*1



### AN60

**8 Station**

Size:6620\*3070\*2400mm

Machine Weight:1100kg

Weight Stack:70kg\*4  
100kg\*4

### AN43

**Multi Station**

Size:1925\*1915\*2375mm

Machine Weight:510kg

Weight Stack:70kg\*3  
100kg\*1

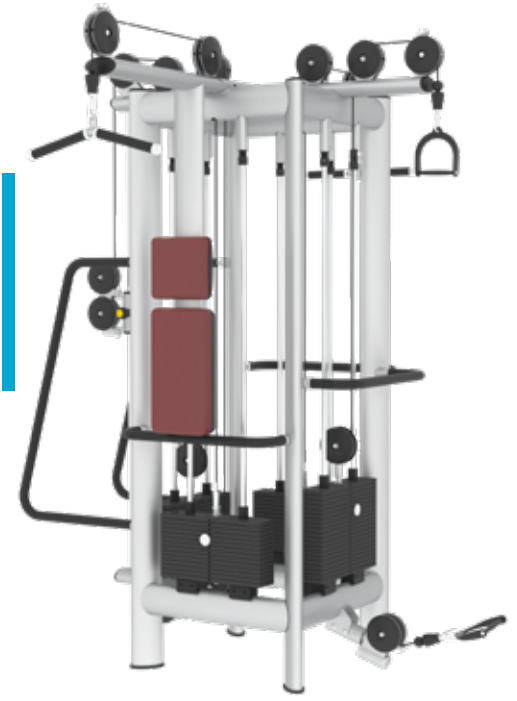

### AN42

**Crossover & Cable Jungle  
( customerized 5 stations)**

Size:5545\*2785\*2705mm

Machine Weight:790kg

Weight Stack:70kg\*2  
115kg\*1  
100kg\*2



# F Series



## Instruction

Clear and concise muscle target makes it easier for trainers to know and learn.

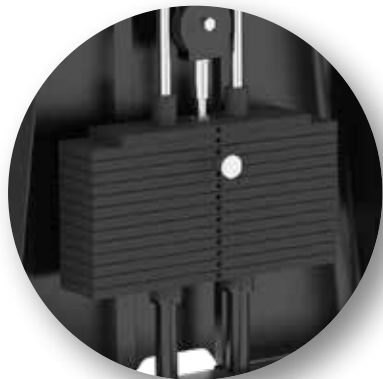

## Updated Weight Stack

The weight can be increased or decreased according to trainer's own situation, and the magnetic pull pin has good safety protection effect.



## Adjuster

Humanization Design Adjustment. Trainers can adjust the position according to personal body condition



## 6mm Thick Steel Cable

Fitness equipment uses 6mm thick steel cable, which is more durable and safer.

**F01****Prone Leg Curl**

Size:1645\*940\*1630mm

Machine Weight:179.5kg

Weight Stack:70kg

**F02****Leg Extension**

Size:1395\*990\*1630mm

Machine Weight:186.5kg

Weight Stack:70kg

**F03****Leg Press**

Size:1960\*1040\*1630mm

Machine Weight:223kg

Weight Stack:100kg

**F04****Butterfly**

Size:1485\*855\*1630mm

Machine Weight:223kg

Weight Stack:70kg

**F05****Lateral Raise**

Size:1255\*825\*1630mm

Machine Weight:169.5kg

Weight Stack:70kg

**F06****Incline Shoulder Press**

Size:1885\*1320\*1630mm

Machine Weight:239kg

Weight Stack:70kg

**F07****Pearl Delt/Pec Fly**

Size:1170\*850\*2030mm

Machine Weight:260kg

Weight Stack:100kg

**F08****Vertical Press**

Size:1380\*1315\*1630mm

Machine Weight:193kg

Weight Stack:70kg



### F09

#### Dip/Chin Assist

Size:1400\*1135\*2345mm

Machine Weight:290.5kg

Weight Stack:100kg



### F11

#### Multi Hip

Size:1295\*1055\*1630mm

Machine Weight:239kg

Weight Stack:70kg



### F13

#### Incline Chest Press

Size:2160\*1430\*1630mm

Machine Weight:239kg

Weight Stack:70kg



### F16

#### Adjustable Crossover

Size:3815\*685\*2280mm

Machine Weight:299kg

Weight Stack:70kg\*2



### F17

#### FTS Glide

Size:1885\*1000\*2295mm

Machine Weight:320.5kg

Weight Stack:70kg\*2



### F18

#### Rotary Torso

Size:1115\*1055\*1630mm

Machine Weight:175kg

Weight Stack:70kg



### F19

#### Abdominal Isolator

Size:1255\*940\*1630mm

Machine Weight:209kg

Weight Stack:70kg



### F20

#### Seated Shoulder Press

Size:1895\*1435\*1630mm

Machine Weight:232.5kg

Weight Stack:70kg



**F21**

**Abductor A**

Size:1550\*890\*1630mm

Machine Weight:214kg

Weight Stack:70kg



**F22**

**Adductor B**

Size:1550\*890\*1630mm

Machine Weight:214kg

Weight Stack:70kg



**F23**

**Leg Curl**

Size:1610\*990\*1630mm

Machine Weight:223kg

Weight Stack:70kg



**F24**

**Glute Isolator**

Size:1185\*1070\*1630mm

Machine Weight:141kg

Weight Stack:70kg



**F25**

**Abductor / Adductor**

Size:1545\*900\*1630mm

Machine Weight:221.5kg

Weight Stack:70kg



**F26**

**Seated Dip**

Size:1600\*1190\*1630mm

Machine Weight:230kg

Weight Stack:70kg



**F28**

**45 Degree Triceps Extension**

Size:1115\*930\*1630mm

Machine Weight:190kg

Weight Stack:70kg



**F30**

**45 Degree Camber Curl**

Size:1225\*920\*1630mm

Machine Weight:167kg

Weight Stack:70kg



### F31

#### Back Extension

Size:1225\*970\*1630mm

Machine Weight:194.5kg

Weight Stack:70kg



### F33

#### Long Pull

Size:1655\*1300\*2040mm

Machine Weight:268kg

Weight Stack:100kg



### F34

#### Vertical Row

Size:1570\*1205\*1630mm

Machine Weight:194kg

Weight Stack:70kg



### F35

#### Pulldown

Size:1235\*1175\*2230mm

Machine Weight:213kg

Weight Stack:100kg



### F85B

#### Abdominal / Back Extension

Size:995\*1195\*1630mm

Machine Weight:198kg

Weight Stack:70kg



### F86B

#### Biceps / Triceps

Size:980\*1220\*1630mm

Machine Weight:182kg

Weight Stack:70kg



### F87B

#### Leg Extension / Curl

Size:975\*1420\*1630mm

Machine Weight:193.5kg

Weight Stack:70kg



### F88

#### Chest / Shoulder Press

Size:2000\*1325\*1630mm

Machine Weight:245.5kg

Weight Stack:70kg



**F89**

**Pull Down/ Long Pull**

Size:2040\*1210\*2330mm

Machine Weight:214kg

Weight Stack:70kg



**F90**

**Prone Leg Curl /  
Leg Extension**

Size:1860\*965\*1630mm

Machine Weight:187.5kg

Weight Stack:70kg



**F95**

**Standing Rear Dearth/  
Pec Fly**

Size:765\*1525\*1650mm

Machine Weight:174.5kg

Weight Stack:70kg



**F97**

**Forearm Trainer**

Size:750\*265\*860mm

Machine Weight:125kg

Weight Stack:100kg



**F14**

**Rotary Rack**

Size:1270\*695\*1290mm

Machine Weight:65kg



**F36**

**Flat Bench**

Size:1410\*560\*430mm

Machine Weight:23kg



**F37**

**Adjustable Decline Bench**

Size:1710\*680\*850mm

Machine Weight:46kg



**F38**

**Multi-Purpose Bench**

Size:1180\*675\*945mm

Machine Weight:21.5kg



### F39

#### Super Bench

Size:1400\*665\*520mm

Machine Weight:37kg



### F41

#### Olympic Decline Bench

Size:2055\*1655\*1235mm

Machine Weight:72kg



### F42

#### Olympic Bench Incline

Size:2030\*1780\*1500mm

Machine Weight:92kg



### F43

#### Olympic Bench

Size:1785\*1775\*1225mm

Machine Weight:58kg



### F44

#### Seated Preacher Curl

Size:1120\*775\*905mm

Machine Weight:43.5kg



### F45

#### Back Extension

Size:1085\*790\*765mm

Machine Weight:43.5kg



### F46

#### Hip Thruster

Size:1540\*1360\*780mm

Machine Weight:83.5kg



### F47

#### Vertical Knee Up/Dip

Size:1175\*815\*1615mm

Machine Weight:96kg



**F48**

**Power Cage**

Size:1320\*1485\*2295mm

Machine Weight:125.5kg



**F49**

**Dumbbell Rack**

Size:2480\*750\*720mm

Machine Weight:64kg

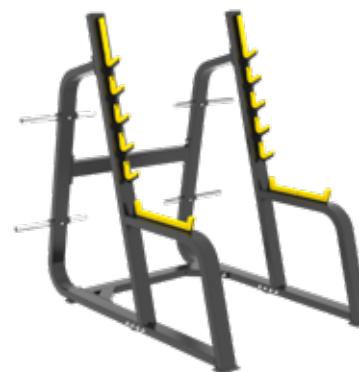

**F50**

**Squat Rack**

Size:1710\*1690\*1800mm

Machine Weight:108.5kg



**F51**

**Olympic Seated Bench**

Size:1775\*1530\*1770mm

Machine Weight:135kg



**F53**

**Handle Rack**

Size:1090\*740\*1070mm

Machine Weight:68kg



**F54**

**Vertical Plate Tree**

Size:630\*540\*1270mm

Machine Weight:25kg



**F55**

**Barbell Rack**

Size:1050\*790\*1460mm

Machine Weight:71kg



**F56**

**Leg Press**

Size:2180\*1650\*1350mm

Machine Weight:220kg



### F57

#### Hack Slide

Size:2250\*1650\*1275mm

Machine Weight:194kg



### F58

#### Leg Press & Hack Slide

Size:2260\*1690\*1430mm

Machine Weight:325kg



### F61

#### Incline Level Row

Size:1735\*1110\*1175mm

Machine Weight:66kg



### F62

#### Seated Calf

Size:1465\*640\*1015mm

Machine Weight:54kg



### F63

#### Smith Machine

Size:2210\*1400\*2435mm

Machine Weight:290kg



### F65

#### Super Squat

Size:1985\*1650\*1415mm

Machine Weight:150kg



### F65B

#### Super Squat

Size:1985\*1560\*1760mm

Machine Weight:150kg



### F70

#### Abdominal Trainer

Size:1530\*930\*1040mm

Machine Weight:60.5kg



**F71**

**Stretch Trainer**

Size:1290\*530\*1090mm

Machine Weight:80kg



**F72**

**Beauty Dumbbell Rack**

Size:1440\*705\*1005mm

Machine Weight:70.5kg



**F73**

**Three-tier  
Dumbbell Rack**

Size:1320\*575\*870mm



**F80**

**Knee Up Chin + Pull Up**

Size:1360\*1465\*2230mm

Machine Weight:115kg



**F84**

**Squat Lunge**

Size:1720\*1500\*845mm

Machine Weight:200kg



**F92**

**Sled**

Size:870\*650\*1115mm

Machine Weight:54kg



**F94**

**Glute Ham Raise Bench**

Size:1640\*810\*1035mm

Machine Weight:84kg



**F96**

**Dual Function  
Preacher Curl**

Size:1245\*725\*1070mm

Machine Weight:83kg



### F98

#### Adjustable Bench

Size:1495\*710\*1120mm

Machine Weight:63.5kg



### F99

#### Adjustable Incline Flat Bench

Size:1290\*570\*475mm

Machine Weight:24kg



### F101

#### Reverse Hyper Extension

Size:2300\*1100\*780mm

Machine Weight:60kg

### F64

#### 8 Multi Station

Size:5130\*4740\*2350mm

Machine Weight:1100kg

Weight Stack:56kg\*2

68kg\*3

100kg\*3

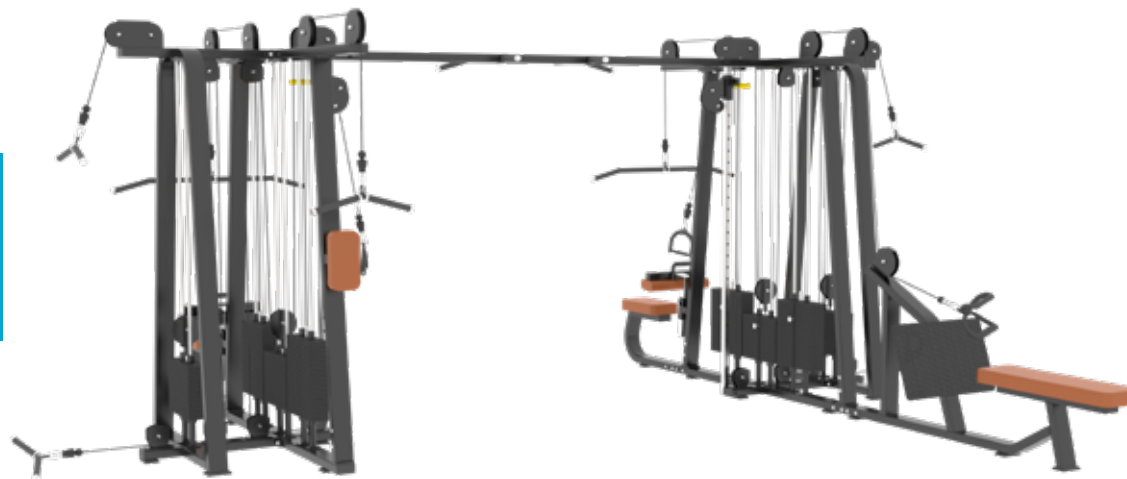

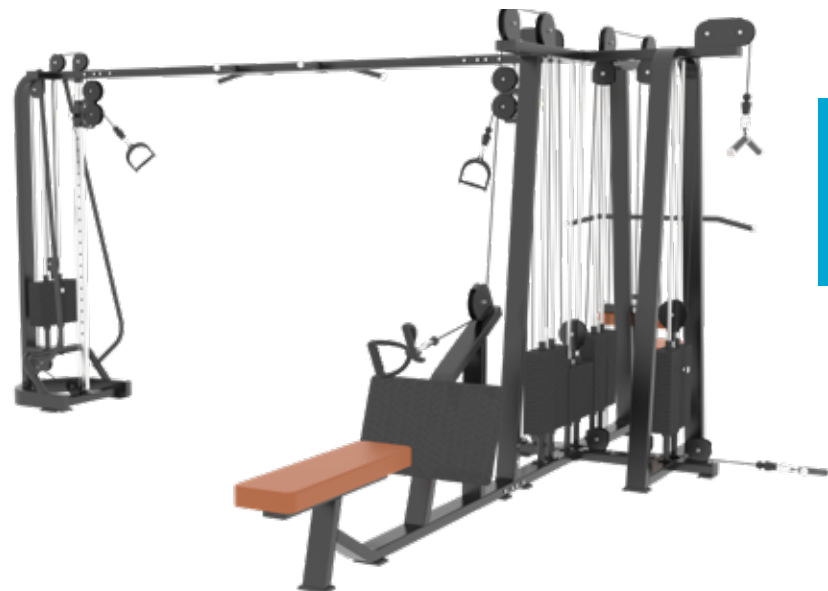

### F81

#### 5 Multi Station (Half F64 & half F16)

Size:4895\*4605\*2345mm

Machine Weight:860kg

Weight Stack:56kg\*2

68kg\*1

100kg\*2



### F82

#### 4 Multi Station

Size:4605\*1415\*2345mm

Machine Weight:600kg

Weight Stack:56kg\*1

68kg\*1

100kg\*2



### F83

#### 8 Multi Station

Size:5170\*4605\*2345mm

Machine Weight:1300kg

Weight Stack:56kg\*2

68kg\*2

100kg\*4

# PL Series



## Grip

Non-slip grip length is reasonable ,angle is scientific,anti-slip effect is obvious.



## Stability

Flat elliptical tube steel frame ,safe and reliable ,never deformed.



## Storage

Comes with weight plate storage bar and functional devices,Storage location for easy use.



## Upholstery

Designed according to ergonomic principles,high-quality PU finishes,the seat can be adjusted in multiple levels,So that exerciser of different sizes can find a suitable exercise method.



**PL01**

**Chest Press**

Size:1925\*1040\*1745mm

Machine Weight:145.5kg



**PL02**

**Incline Press**

Size:1940\*1400\*1800mm

Machine Weight:120.5kg



**PL03**

**Shoulder Press**

Size:1530\*1475\*1500mm

Machine Weight:112kg



**PL04**

**Seated Dip**

Size:1975\*1015\*1005mm

Machine Weight:116kg



**PL05**

**Biceps Curl**

Size:1475\*925\*1265mm

Machine Weight:97kg



**PL06**

**Pulldown**

Size:1825\*1455\*2040mm

Machine Weight:126.5kg



**PL07**

**Low Row**

Size:1680\*1310\*1700mm

Machine Weight:117kg



**PL08**

**Rowing**

Size:1455\*1385\*1270mm

Machine Weight:114kg



### PL09

#### Leg Curl

Size:1540\*1275\*1370mm

Machine Weight:115kg



### PL10

#### Leg Extension

Size:1850\*1530\*1210mm

Machine Weight:112.5kg



### PL11

#### Standing / Seated Shrug

Size:1630\*1155\*1160mm

Machine Weight:106kg



### PL12

#### Iso-lateral Horizontal Bench Press

Size:1915\*1750\*1010mm

Machine Weight:109.5kg



### PL13

#### Super Incline Chest Press

Size:1700\*1315\*1545mm

Machine Weight:130kg



### PL14

#### Decline Chest Press

Size:1755\*1130\*1805mm

Machine Weight:129kg



### PL15

#### Wide Chest Press

Size:1920\*1270\*1845mm

Machine Weight:145.5kg



### PL16

#### Iso-Lateral Chest Press / Pulldown

Size:1915\*1675\*2120mm

Machine Weight:172kg



**PL17**

**Iso-Lateral Front Lat Pulldown**

Size:1670\*1615\*2080mm

Machine Weight:141kg



**PL18**

**D.Y Row**

Size:1630\*1390\*2050mm

Machine Weight:147kg



**PL19**

**Gripper**

Size:1230\*660\*940mm

Machine Weight:47kg



**PL20**

**Abdominal Oblique Crunch**

Size:1485\*1200\*1700mm

Machine Weight:126kg



**PL21**

**Iso-Lateral Leg Curl**

Size:1755\*1320\*940mm

Machine Weight:92.5kg



**PL22**

**Iso-Lateral Leg Press**

Size:1890\*1198\*1430mm

Machine Weight:190.5kg



**PL23**

**Tibia Dorsi Flexion**

Size:1110\*345\*345mm

Machine Weight:25kg



**PL24**

**Hip Builder**

Size:1575\*1625\*1420mm

Machine Weight:168kg



**PL25**  
**Side Arm Lifting Trainer**  
Size:1235\*1375\*1265mm  
Machine Weight:89.5kg



**PL26**  
**Arm Press Back**  
Size:1725\*1865\*1475mm  
Machine Weight:134kg



**PL27**  
**Standing Calf**  
Size:1270\*1455\*1565mm  
Machine Weight:89kg



**PL28**  
**Shoulder Press**  
Size:1120\*1856\*1745mm  
Machine Weight:99.5kg



**PL29**  
**Abductor**  
Size:1750\*1185\*1185mm  
Machine Weight:108.5kg



**PL30**  
**Adductor**  
Size:1680\*1180\*1170mm  
Machine Weight:109kg



**PL31**  
**V- Squat**  
Size:2015\*1610\*1650mm  
Machine Weight:152kg



**PL32**  
**Abdominal Trainer**  
Size:1100\*520\*485mm  
Machine Weight:30kg



**PL33**

**Decline Chest Press**

Size:2155\*1785\*1025mm

Machine Weight:119kg



**PL34**

**Seated Leg Curl**

Size:1600\*1455\*1255mm

Machine Weight:112kg



**PL35**

**Abdominal & Knee Up/Dip**

Size:2545\*770\*1720mm

Machine Weight:102.5kg



**PL36**

**Lat Pulldown**

Size:1655\*1415\*2085mm

Machine Weight:135kg



**PL37**

**Multi-angle Chest Push Trainer**

Size:2080\*2100\*2075mm

Machine Weight:251kg



**PL38**

**Squat Machine**

Size:1915\*990\*1935mm

Machine Weight:122kg



**PL39**

**Bent-Over Row**

Size:1735\*1660\*1245mm

Machine Weight:189kg



**PL40**

**Glute Builder**

Size:1845\*1680\*1245mm

Machine Weight:145kg



**PL42**  
**3D Multi Angle Hip Abduction Trainer**  
Size:1805\*960\*1405mm



**PL43**  
**Pendulum Style Back Kick Trainer**  
Size:1515\*1295\*1400mm



**PL44**  
**Kneeling Hip Punch Trainer**  
Size:1770\*1315\*1510mm



**PL45**  
**Dual Directional 45 Degree Extension**  
Size:1545\*1131\*1155mm



**PL56**  
**Linear Leg Press**  
Size:2425\*1415\*1505mm  
Machine Weight:244kg



**PL57**  
**Linear Hack Squat**  
Size:2180\*1610\*1500mm  
Machine Weight:184.5kg



**PL61**  
**Incline Lever Row**  
Size:1845\*1330\*1155mm  
Machine Weight:70kg



**PL62**  
**Calf Raise**  
Size:1455\*740\*1045mm  
Machine Weight:53.5kg



**PL65**

**Squat**  
 Size:2285\*1760\*1565mm  
 Machine Weight:218.5kg



**PL66**

**Standing Press**  
 Size:2080\*1550\*2105mm  
 Machine Weight:134kg



**PL67**

**Standing Incline Press**  
 Size:1945\*1915\*1925mm  
 Machine Weight:132.5kg



**PL68**

**Standing Decline Press**  
 Size:1890\*1440\*2560mm  
 Machine Weight:145kg



**PL69**

**Squat Lunge**  
 Size:1600\*1525\*790mm  
 Machine Weight:96.5kg



**PL73B**

**Hip Thrust Machine**  
 Size:1765\*1650\*840mm  
 Machine Weight:100.5kg



**PL74**

**Hip Belt Squat Machine**  
 Size:1810\*1380\*1150mm  
 Machine Weight:143.5kg



**PL75**

**Incline Chest Fly Machine**  
 Size:1545\*1470\*1090mm  
 Machine Weight:65kg



**PL76**

**Vertical Leg Press**  
 Size:1505\*1335\*1900mm  
 Machine Weight:165kg

# G Series



## Handlebar

The length of the aluminum alloy handlebar is reasonable, the angle is scientific, and the anti-slip effect is obvious.



## Moving Arm

Bold yellow moving arm highlights the entire series, with bright yellow and black main frame for perfect color matching



## Bearing

Steel shaft bearing, aluminum bearing cap, no noise during movement, no resistance, durable.



## Seat

Designed according to ergonomic principles, high-quality PU leather, the seat can be adjusted in multiple steps, so that different body types of athletes can find their own exercise posture.

**G05****Chest Press**

Size:1720\*1395\*1720mm

Machine Weight:165kg

**G10****Wide Chest Press**

Size:1270\*1525\*1775mm

Machine Weight:165kg

**G15****Incline Chest Press**

Size:1550\*1040\*1665mm

Machine Weight:163kg

**G20****Pulldown**

Size:1750\*1275\*1995mm

Machine Weight:152kg

**G25****Low Row**

Size:1310\*1280\*1630mm

Machine Weight:135.5kg

**G30****Incline Level Row**

Size:1430\*1195\*1295mm

Machine Weight:125.5kg

**G35****Shoulder Press**

Size:1180\*1300\*1500mm

Machine Weight:130kg

**G40****Rear Kick**

Size:1490\*1130\*1685mm

Machine Weight:120.5kg



### G45

#### Calf

Size:1715\*1190\*1210mm

Machine Weight:198kg



### G50

#### Leg Press

Size:2040\*1460\*1405mm

Machine Weight:264kg



### G55

#### Leg Extension

Size:1545\*1340\*1015mm

Machine Weight:98.5kg



### G60

#### Seated Dip

Size:1670\*1550\*1110mm

Machine Weight:160kg



### G65

#### Biceps

Size:1180\*1585\*985mm

Machine Weight:150kg



### G70

#### Standing Leg Curl

Size:1415\*1120\*1295mm

Machine Weight:120kg



### G75

#### Linear Leg Press

Size:2750\*1700\*1490mm

Machine Weight:340kg

# H Series



## Steel Pipe

Stable, durable and not easy to rust



## Handlebar

The handlebar the non-slip handle make it easy for the exerciser to adjust to the proper posture ,which makes the referral training more suitable.



## Hydraulic Cylinder

Six different gears provide different resistance to the trainer, allowing different trainers to find the right way to exercise.



## Seat

Designed according to ergonomics, high quality PU leather. The seat can be adjusted in multiple steps,so that different body types of athletes can find a suitable posture for themselves.

H series commercial hydraulic cylinder cycle trainer is a series of strength training equipment. The H-series is ideal for fitness, slimming and improving health, and offers fitness enthusiasts a different fitness style than traditional gym training. The H cycle training equipment converts the fluid energy of the hydraulic cylinder into a linear motion of reciprocating push or pull in the cylinder, and the movement is smoother and simpler. Each model exercises a training session and a series is a professional fitness mode. Safe to use, less to sports injuries, create a harmonious training atmosphere for trainers, especially for middle-aged and older trainers. The hydraulic cylinder can adjust different resistances, and the trainer sets the appropriate gear position. This series uses high-grade aluminum alloy hydraulic cylinders. The installation design of hydraulic cylinders is safe and reliable, and the sport mode conforms to the human body simulation exercise track. Easy to move to suit the needs of the site, aluminum joints are used for each joint, and cushions and cushions use environmentally friendly materials.



## H01

### Chest press

Size:970\*700\*1300mm

Machine Weight:43kg



## H02

### Pec Fly/Rear Deltoid

Size:970\*840\*1270mm

Machine Weight:43.5kg



## H03

### Overhead Press / Pulldown

Size:970\*700\*1645mm

Machine Weight:45.5kg



## H04

### Biceps Curl/ Triceps Extention

Size:1140\*690\*880mm

Machine Weight:33kg



### H05

**Leg Extension / Leg Curl**

Size:1395\*744\*1340mm

Machine Weight:47kg



### H06

**Hip Abductor/Adductor**

Size:1340\*950\*1305mm

Machine Weight:50kg



### H07

**Leg press**

Size:1595\*650\*1555mm

Machine Weight:54kg



### H08

**Squat**

Size:1410\*700\*1195mm

Machine Weight:46kg



### H09

**Abdominal Crunch/  
Back Extension**

Size:1210\*800\*1075mm

Machine Weight:40.5kg



### H10

**Rotary Torso**

Size:1015\*930\*935mm

Machine Weight:43kg



### H11

**Glute Isolator**

Size:1240\*945\*1175mm

Machine Weight:68kg



### H12

**Shoulder Lift Trainer**

Size:770\*900\*1125mm

Machine Weight:45.5kg

# HA Series



## HA01

ISO Lateral Incline Press

Size: 1435\*1666\*1978mm

Machine Weight: 139kg



## HA02

ISO Lateral High Row

Size: 1837\*1620\*2000mm

Machine Weight: 149kg



## HA03

ISO Lateral Leg Press

Size: 1989\*1770\*1544mm

Machine Weight: 148kg



## HA04

ISO Wide Chest Press

Size: 1323\*1600\*1746mm

Machine Weight: 140kg



**HA05**

**ISO Seated Chest Press & Lat Pulldown**  
 Size:1850\*1770\*2000mm  
 Machine Weight:160kg



**HA06**

**ISO Lateral Rowing**  
 Size:1558\*1426\*1467mm  
 Machine Weight:128kg



**HA07**

**ISO Lateral Wide Chest**  
 Size:1313\*1980\*1760mm  
 Machine Weight:141kg



**HA08**

**Squat Lunge**  
 Size:1358\*1617\*873mm  
 Machine Weight:100kg



**HA09**

**Smith Machine**  
 Size:1340\*2266\*2384mm  
 Machine Weight:215kg



**HA10**

**Olympic Military Bench**  
 Size:1763\*1210\*1670mm  
 Machine Weight:88kg



**HA13**

**ISO Lateral DY Rowing**  
 Size:1455\*1476\*2133mm  
 Machine Weight:135kg



**HA14**

**Weight Plate Tree**  
 Size:710\*610\*1025mm  
 Machine Weight:37kg



### HA15

#### ISO Lateral Super Incline Press

Size:1500\*1350\*1650mm

Machine Weight:137kg



### HA16

#### ISO Lateral Lat Pulldown

Size:1650\*1100\*2050mm

Machine Weight:145kg



### HA17

#### ISO Lateral Leg Extension

Size:1433\*1477\*1470mm

Machine Weight:126kg



### HA18

#### ISO Lateral Prone Leg Curl

Size:1550\*1300\*800mm

Machine Weight:128kg



### HA19

#### 45 Degree Leg Press

Size:2350\*1855\*1500mm

Machine Weight:251kg



### HA20

#### Seated Arm Curl

Size:1000\*800\*1120mm

Machine Weight:72kg



### HA21

#### ISO Lateral Shoulder Press

Size:1500\*1250\*1900mm

Machine Weight:139kg



### HA22

#### Squat High Pull

Size:1650\*1150\*1051mm

Machine Weight:99kg



### HA23

**Seated Calf Raise**

Size:1230\*730\*1004mm

Machine Weight:65kg



### HA24

**Seated Calf**

Size:1673\*1630\*1500mm

Machine Weight:135kg



### HA25

**ISO Lateral Low Row**

Size:1250\*1056\*1700mm

Machine Weight:139kg



### HA26

**ISO Deline Chest Press**

Size:1300\*1150\*1750mm

Machine Weight:141kg



### HA27

**ISO Lateral Wide Lat Pulldown**

Size:1800\*1100\*2150mm

Machine Weight:141kg



### HA28

**ISO Laydown Chest Press**

Size:1700\*1400\*1200mm

Machine Weight:112kg



### HA29

**Seated Biceps**

Size:1466\*1292\*1502mm

Machine Weight:93kg



### HA30

**Standing Press**

Size:2092\*1790\*2252mm

Machine Weight:142kg



### HA31

#### Olympic Squat Rack

Size:1763\*1210\*1670mm

Machine Weight:88kg



### HA34

#### Flat Bench

Size:1295\*595\*457mm

Machine Weight:23kg



### HA35

#### Tension Machine

Size:1545\*1350\*1710mm

Machine Weight:130kg



### HA36

#### Gripper

Size:1075\*580\*855mm

Machine Weight:53kg



### HA37

#### Seated Leg Extension

Size:1440\*1695\*1480mm

Machine Weight:104kg



### HA38

#### Olympic Flat Bench

Size:2000\*1150\*1150mm

Machine Weight:78kg



### HA40

#### Adjustable Bench

Size:1380\*664\*455mm

Machine Weight:40kg



### HA41

#### Tibia Dorsi Flexion

Size:950\*380\*336mm

Machine Weight:27kg



**HA42**

**Olympic Incline Bench**  
 Size:1400\*1286\*1600mm  
 Machine Weight:69kg



**HA45**

**Adjustable Abdominal Bench**  
 Size:1215\*680\*1070mm  
 Machine Weight:40kg



**HA46**

**Multi-functional Bench**  
 Size:2070\*1180\*1270mm  
 Machine Weight:95kg



**HA48**

**ISO-Lateral Rear Deltoid**  
 Size:1920\*1050\*880mm  
 Machine Weight:90kg



**HA49**

**Fore Arm**  
 Size:750\*1110\*445mm  
 Machine Weight:65kg

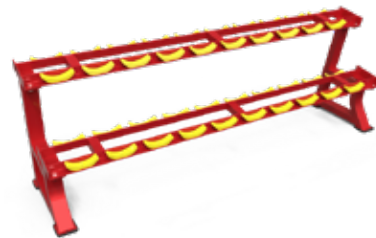

**HA50**

**Dumbbell Rack**  
 Size:2105\*590\*780mm  
 Machine Weight:58kg



**HA51**

**75 Degree Utility**  
 Size:1120\*640\*1145mm  
 Machine Weight:28kg



**HA52**

**Flat Bench**  
 Size:1270\*470\*430mm  
 Machine Weight:55kg



### HA55

**Adjustable Decline Bench**

Size:1400\*680\*600mm

Machine Weight:48kg



### HA56

**Incline Pec Fly**

Size:1350\*1650\*1350mm

Machine Weight:92kg



### HA58

**Lateral Raise**

Size:1050\*1506\*1300mm

Machine Weight:102kg



### HA59

**Abductor**

Size:1690\*730\*750mm

Machine Weight:139kg

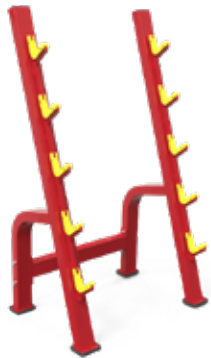

### HA61

**Barbell Rack**

Size:780\*620\*1450mm

Machine Weight:80kg



### HA63

**4 Way Neck**

Size:900\*1400\*1600mm

Machine Weight:130kg



### HA64

**Comprehensive Incline**

Size:1800\*1650\*1830mm

Machine Weight:138kg

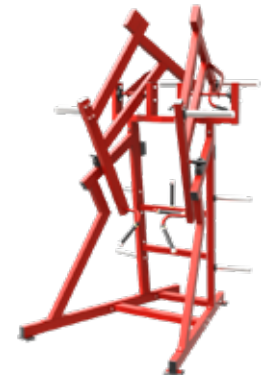

### HA65

**Comprehensive Decline**

Size:1650\*1300\*2440mm

Machine Weight:163kg



### HA66

**ISO Lateral Knee Leg Curl**

Size:1270\*1000\*1290mm

Machine Weight:145kg



### HA67

**Seated Dip**

Size:1710\*970\*1070mm

Machine Weight:130kg



### HA68

**Pull Over**

Size:1231\*1360\*1503mm

Machine Weight:120kg



### HA70

**Adductor**

Size:1690\*730\*750mm

Machine Weight:139kg



### HA71

**V-Squat**

Size:2430\*1450\*1810mm

Machine Weight:242kg



### HA72

**Abdominal**

Size:1670\*1100\*1600mm

Machine Weight:121kg



### HA73

**Olympic Decline Bench**

Size:1500\*1150\*1280mm

Machine Weight:65kg



### HA80

**Stand Calf**

Size:1200\*1208\*1503mm

Machine Weight:124kg



### HA82

**Strength Hip and Glute**

Size:1250\*1750\*1090mm

Machine Weight:65kg



### HA83

**Seated Triceps Extension**

Size:1355\*1330\*1410mm

Machine Weight:90kg



### HA84

**Abdominal Trainer**

Size:980\*485\*540mm

Machine Weight:34kg



### HA85

**Barbell Rack**

Size:940\*820\*1510mm

Machine Weight:72kg



### HA86

**Adjustable Bench**

Size:1760\*670\*485mm

Machine Weight:39kg



### HA88

**Back Extension**

Size:1552\*770\*876mm

Machine Weight:42kg



### HA89

**Vertical Leg Press**

Size:1300\*1050\*1800mm

Machine Weight:122kg

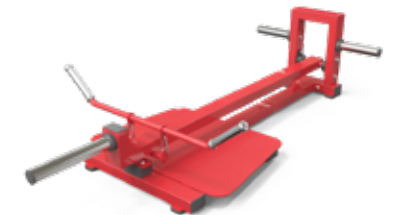

### HA90

**T Level Row**

Size:2296\*1136\*920mm

Machine Weight:76kg



### HA93

#### Decline Chest Press

Size:1730\*2070\*1110mm

Machine Weight:90kg



### HA95

#### Fixed Pad Glute

Size:1830\*840\*1270mm

Machine Weight:150kg



### HA96

#### Linear Hack Press

Size:2350\*1855\*1500mm

Machine Weight:251kg



### HA97

#### Olympic Power Rack & Pull Up

Size:1785\*1365\*2235mm

Machine Weight:165kg



### HA98

#### Seated Leg Curl

Size:1440\*1695\*1484mm

Machine Weight:103kg



### HA103

#### Adjustable Bench

Size:1470\*550\*420mm

Machine Weight:40kg



### HA116

#### Shoulder Lifting Machine

Size:1358\*980\*1445mm

Machine Weight:83kg



### HA117

#### Shoulder Double Sided Lifting Machine

Size:1358\*980\*1445mm

Machine Weight:83kg

# E360 Series

## Multifunctional Power Rack

More training areas, can carry out a number of distinctive fitness exercises, allowing customers to get a more comprehensive fitness effect, the functional training area has multiple elements, including physical combat, bounce, pull-ups, sports belt functional training, core stability training, team training, strength training, balance, endurance, speed, flexibility, etc.

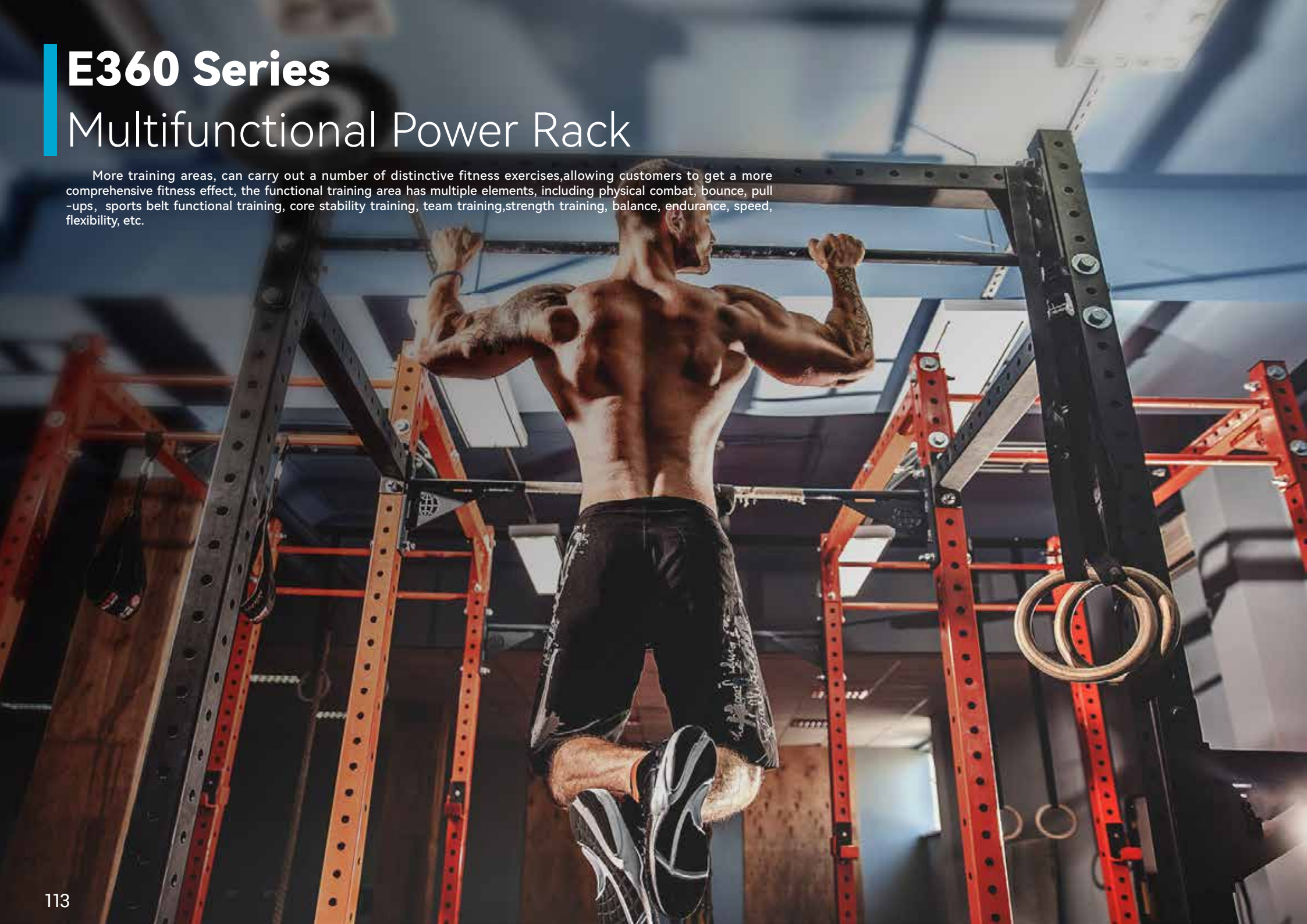



## E360-A

### Synergy 360(8 gates) with whole set of accessories

**Accessories:** Rope:4pcs

Climbing rope:1pc

Small trampoing:1 pc

Boxing bag:1pc

Olympic bar:1pc

Kettle-bell:1set

Medicin ball:1set

Size(L\*W\* H):8330\*5630\*2550mm

## E360-B

### Synergy 360(6 gates) with whole set of accessories

**Accessories:** Rope:4pcs

Climbing rope:1pc

Small trampoing:1 pc

Boxing bag:1pc

Olympic bar:1pc

Kettle-bell:1set

Medicin ball:1set

Size(L\*W\* H):4430\*4025\*2550mm





## E360-E

### Synergy 360(4 gates) with whole set of accessories

**Accessories:** Rope:2pcs

Climbing rope:1pc

Small trampoing:1 pc

Boxing bag:1pc

Olympic bar:1pc

Kettle-bell:1set

Medicin ball:1set

Size(L\*W\* H):3530\*3160\*2345mm

## E360-F

### Synergy 360(4 gates) with whole set of accessories

**Accessories:** Rope:2pcs

Climbing rope:1pc

Small trampoing:1 pc

Boxing bag:1pc

Olympic bar:1pc

Kettle-bell:1set

Medicin ball:1set

Size(L\*W\* H):5065\*2955\*2345mm



## E360-K

### Synergy 360 (6 Stations + 1 Smith Machine) + whole set of accessories

**Accessories:** Rope:2pcs

Climbing rope:1pc

Small trampoing:1 pc

Boxing bag:1pc

Olympic bar:1pc

Kettle-bell:1set

Medicin ball:1set

Size(L\*W\* H):5070\*4150\*2410mm

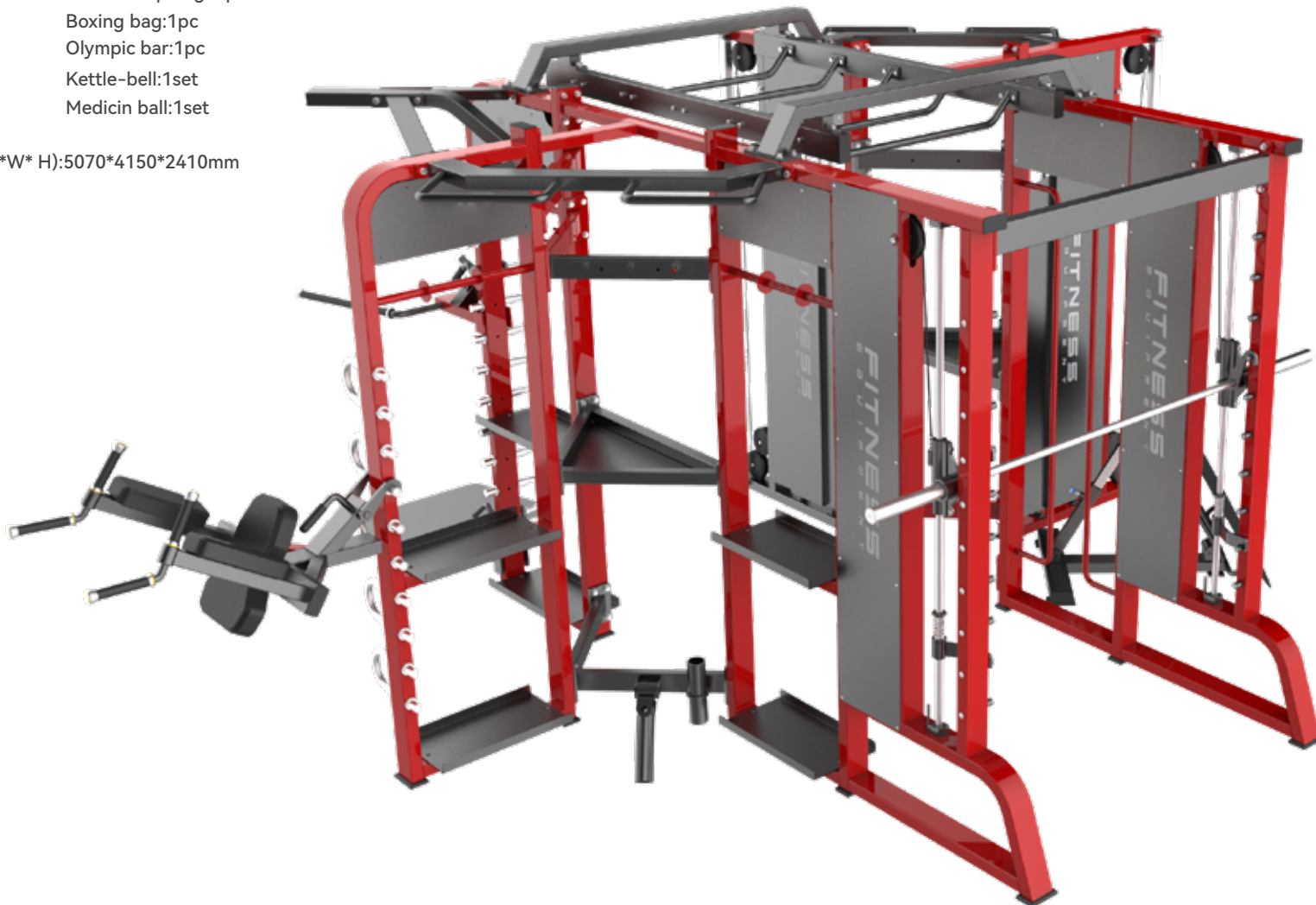

# C Series





### C83B

**Adjustable Dumbbell**  
 Size:430\*210\*210mm  
 Professional Training  
 Machine Weight:25kg



### C73A

**Adjustable Dumbbell  
 (1Pair+Bracket)**  
 Size:340\*270\*125mm  
 Machine Weight:15kg



### C73B

**Adjustable Dumbbell  
 (1Pair+Bracket)**  
 Size:380\*335\*130mm  
 Machine Weight:15kg



### C43

**Sissy Squat**  
 Size:875\*715\*500mm  
 Machine Weight:24.5kg



### C80

**Multi-functional  
 Smith Machine**  
 Size:1970\*1700\*2280mm  
 Machine Weight:270.5kg



### C81

**Multi-functional  
 Smith Machine**  
 Size:2000\*1500\*2280mm  
 Machine Weight:390.5kg



### C90

**Multi-functional  
 Smith Machine**  
 Size:1965\*2035\*2280mm  
 Machine Weight:448kg



### C86

**Multi-functional  
 Smith Machine**  
 Size:2005\*1920\*2280mm  
 Machine Weight:577kg



**C75**  
**Multi-Bench**  
Size:1500\*710\*1120mm  
Machine Weight:47.5kg



**C85**  
**Multi-functional Squat Rack**  
Size:1720\*1475\*2350mm  
Machine Weight:146kg



**C95**  
**Standing Abductor**  
Size:1720\*830\*1480mm  
Machine Weight:158kg



**C74**  
**Free Weight Multi-gym**  
Size:1510\*1440\*2125mm  
Machine Weight:95kg



**C45**  
**Calf Stretcher**  
Size:640\*390\*120mm  
Machine Weight:8kg



**C88**  
**Dumbbell Rack**  
Size:540\*575\*570mm



**TXD030**  
**3D Smith Machine**  
Size:2585\*2205\*2425mm  
Machine Weight:113kg



**C53**  
**Training Rack**  
Size:4440\*3590\*2805mm  
Machine Weight:350kg

**C03****Overhanging TRX Rack**

Size:2605\*2180\*2790mm

Machine Weight:113kg

**C05****Overhanging TRX Rack**

Size:5220\*4090\*2370mm

Machine Weight:229kg

**C07****Free Training Rack**

Size:5500\*2480\*2850mm

Machine Weight:389kg

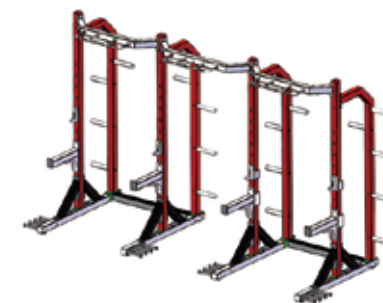
**C09****Bench Press Rack**

Size:4325\*1505\*2550mm

Machine Weight:358kg

**C12****Customized Squat Rack**

Size:1815\*1405\*2505mm

Machine Weight:158kg

**C13****Free Training Rack**

Size:5500\*2481\*2853mm

Machine Weight:397kg

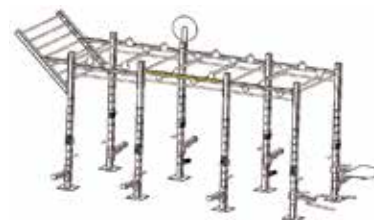
**C15****Climbing Ladder**

Size:6155\*2695\*3020mm

Machine Weight:397kg

**C16****Climbing Ladder**

Size:9880\*3095\*3695mm

Machine Weight:822kg



### C17

#### Frame Squat Ladder

Size:4505\*1530\*2460mm

Machine Weight:330kg



### C18

#### Parallel Ladder

Size:4470\*680\*2415mm

Machine Weight:177kg



### C19

#### Wall Rack

Size:4070\*1600\*3005mm

Machine Weight:163kg

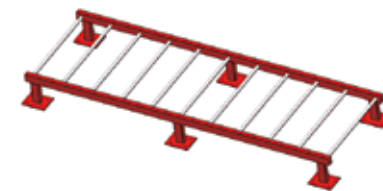

### C20

#### Wall Rack

Size:3150\*1130\*300mm

Machine Weight:74kg

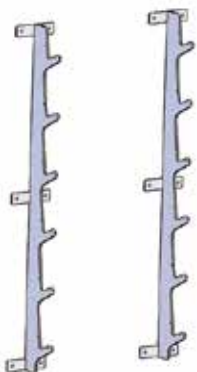

### C21

#### Wall Rack

Size:200\*205\*1550mm

Machine Weight:35kg



### C22

#### Sandbag Rack

Size:800\*1405\*2145mm

Machine Weight:63kg



### C24

#### Combination Training Frame

Size:9020\*3810\*4050mm

Machine Weight:1762kg



### C25

#### Climbing Ladder

Size:5800\*3485\*3695mm

Machine Weight:576kg



### C26

#### Wall Training Rack

Size:725\*1420\*2400mm

Machine Weight:106kg



### C30

#### Climbing Ladder

Size:7080\*3245\*2605mm

Machine Weight:707kg



### C31

#### Wall Rack

Size:4970\*2120\*3010mm

Machine Weight:181kg



### C33

#### Commodity Shelf

Size:2140\*640\*1460mm

Machine Weight:108kg



### C34

#### Climbing Ladder

Size:7080\*3245\*2610mm

Machine Weight:765kg



### C35

#### Training Rack

Size:7040\*1715\*3125mm

Machine Weight:244kg



### C36

#### Climbing Ladder

Size:6130\*3245\*2610mm

Machine Weight:735kg

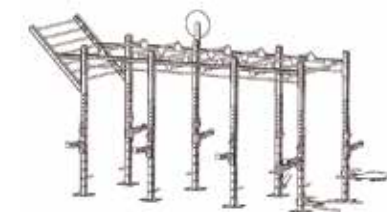

### C37

#### Climbing Ladder

Size:6155\*2705\*3040mm

Machine Weight:506kg



### C38

#### Climbing Ladder

Size:7080\*3250\*3130mm

Machine Weight:787kg

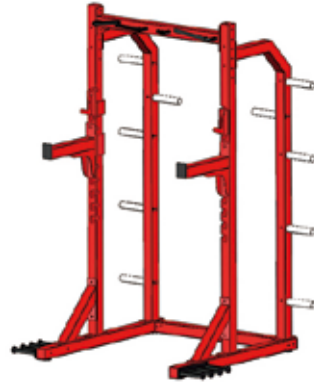

### C42

#### Customized Squat Rack

Size:1775\*1405\*2475mm

Machine Weight:152kg



### C44

#### Climbing Ladder

Size:8015\*3090\*3700mm

Machine Weight:767kg

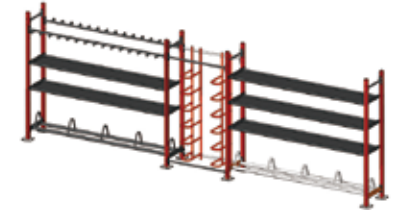

### C52

#### Big Commodity Shelf

Size:5920\*660\*2010mm

Machine Weight:506kg



### C46

#### Wall Training Rack

Size:5085\*2605\*3470mm

Machine Weight:221kg

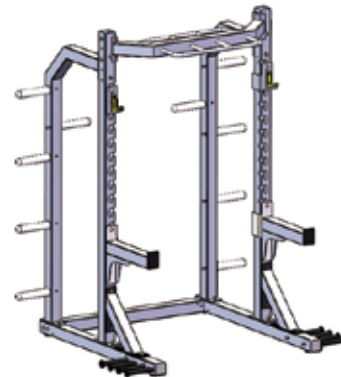

### C47

#### Bench Press Frame

Size:1815\*1405\*2175mm

Machine Weight:161.5kg



### C50

#### Wall Training Rack

Size:5160\*1600\*3070mm

Machine Weight:244kg

# Accessories Series



## WG001

### Dumbbell

Machine Weight:2.5kg-50kg  
7.5kg...50kg



## WG425

### HealthFit Dumbbell

Machine Weight:2.5kg/5kg/  
7.5kg/...50kg



## WG424

### HealthFit Weight Plate

Machine Weight:2.5KG/5KG/  
10KG/15KG/  
20KG/25KG



## WG012

### 3 Holes Weight Plate

Machine Weight:2.5kg/5kg/  
10kg/15kg/  
20kg/25kg



### WG055

**Adjustable Barbell**

Machine Weight:1kg/2.5kg/5kg



### WG260

**Fitness Handles**

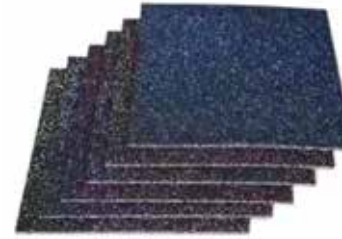

### WG255

**Rubber Flooring**

Size:500x500mm



### LL135

**BIA Physical  
Fitness Instrument**

Size:799\*452.5\*1100mm

Machine Weight:16kg



This catalogue is only for your reference. If any difference about color or size, please contact your sales for final interpretation and thank you for your understanding